

Customer Care Solutions

RH-19 Cellular Phone

6 – Baseband Description & Troubleshooting

Table of Contents

Description	Page No.
Baseband Top-level Description	5
Baseband Block Diagram	5
RH-19 Baseband Feature List	6
Environmental Specifications	6
Normal and Extreme Voltages	6
Temperature Conditions	6
Humidity	6
Frequencies in Baseband	7
Printed Wire Board (PWB)	7
Baseband Architecture	7
Baseband Core	7
Universal Phone Processor (UPP)	7
Universal Energy Management (UEMK)	8
External Flash and External SRAM	8
Energy Management	8
Power Supply Modes	9
Battery BL-5C/BL-5R	12
Power Distribution	12
DC Characteristics	14
Charging	15
Audio Circuitry	15
Audio Block Diagram	16
Earpiece	16
Microphone	16
Integrated Hands-free (IHF)	17
Audio Accessory Receive Path	17
Audio Control Signals	17
Acoustics	17
Earpiece Acoustic	17
IHF Speaker Acoustic	18
Microphone Acoustic	19
Vibra Motor	19
Audio Modes	19
Hand Portable Mode	20
Integrated Hands-free Audio Mode	20
Headset Audio Mode	20
Loopset Audio Mode	21
External Hands-free Audio Mode	21
User Interface	21
LCD Module	21
Baseband LCD Interface	21
DC Characteristics	22
Current Consumption	23
Maximum Ratings	23
AC Characteristics	23

Description	Page No.
Rest Timing	24
Display Power On/Off Sequence	25
LED Power Supply	25
Keypad	26
SIM Interface	26
BB-RF Interface	27
Digital Signals between BB and RF	28
Analog Signals between BB and RF	28
Voltage Regulators in BB for RF	30
System Connector Interface	31
System Connector	31
Accessory Control Interface (ACI)	32
Signal Flow on ACI line ACI-ASIC accessory inserted	33
Signal Flow on ACI line Non ACI-ASIC accessory inserted	34
FBUS	35
VOUT (Accessory Voltage Regulator)	35
HookInt	36
Charging	37
DC-Plug	37
VCHAR Pins of System Connector	37
Voltages and Currents	37
Baseband Calibration	38
Energy Management Tuning	38
Calibration method with JBV-1	38
Calibration method without JBV-1	39
LCD Contrast Tuning	40
Baseband Testpoints	42
List and Description	42
Testpoints on Bottom-side	44
Testpoints on Top-side	45
Baseband Troubleshooting	46
Top Level Flowchart	47
Phone is Dead	49
Flash Faults	51
Phone is Jammed	53
Charger	56
SIM Card Error	57
Audio Faults	58
Earpiece Fault	62
Display Fault	63
Keypad Fault	65
Selftest Fault	67
Active Cover Interface	68

	Description	Page No.
List of Figures		
Figure 1	Baseband block diagram	5
Figure 2	UEMK state diagram	9
Figure 3	Baseband power distribution	13
Figure 4	Charging configuration	15
Figure 5	Audio block diagram	16
Figure 6	Earpiece implementation	18
Figure 7	Exploded view of antenna assembly	19
Figure 8	LCD connector	22
Figure 9	Write characteristics	23
Figure 10	Rise and fall time in input and output	24
Figure 11	Reset timing	24
Figure 12	Power on/off sequence	25
Figure 13	RH-19 keypad	26
Figure 14	UPP, UEMK and SIM connections	27
Figure 15	Pop Port System Connector	32
Figure 16	Principle schematics of ACI Accessory and Engine	33
Figure 17	ACI communication	33
Figure 18	Signal Flow on ACI line	34
Figure 19	Accessory Power Supply Diagram	35
List of Tables		
Table 1	Frequency list	7
Table 2	UEMK regulator outputs	14
Table 3	Handportable mode audio routing	20
Table 4	IHF mode audio routing	20
Table 5	Headset mode audio routing	20
Table 6	Loop set mode audio routing	21
Table 7	External hands-free mode audio routing	21
Table 8	LCD interface DC characteristics	22
Table 9	LCD interface current consumption	23
Table 10	LCD interface maximum ratings	23
Table 11	AC characteristics	24
Table 12	Rise and fall times in input and output of display	24
Table 13	Reset timing	25
Table 14	RF-BB interface digital signals	28
Table 15	RF-BB interface analog signals	29
Table 16	Voltage supplies and references	30
Table 17	System connector interface description	32
Table 18	Voltage levels	34
Table 19	FBUS interface	35
Table 20	Accessories power supply	36
Table 21	Voltage levels Hook Int	36
Table 22	Charger input voltage levels	37
Table 23	System connector interface signals	37
Table 24	BB Calibration limits	38
Table 25	RH-19 test points	42

Baseband Top-Level Description

Product RH-19 is a hand portable EGSM900, GSM1800, GSM1900 DCT-4 generation phone for the expression segment, with optional active covers available.

The RH-19 Baseband consists of the DCT4 common Baseband chipset having some product specific blocks of its own, such as pop-port system connector (also unofficially known as "Tomahawk"), IHF and a color display.

The Baseband engine consists basically of two major ASIC's.

- The UEMK is the Universal Energy Management IC. It includes the analog audio circuits, the charge control and voltage regulators. (The 'K' just provides the information that this is a shrunk version of the UEM. There is no difference in functionality between UEM and UEMK)
- The UPP is the Universal Phone Processor and contains DSP, MCU and some internal memory.

Baseband Block Diagram

The below system block shows the main BB function blocks.

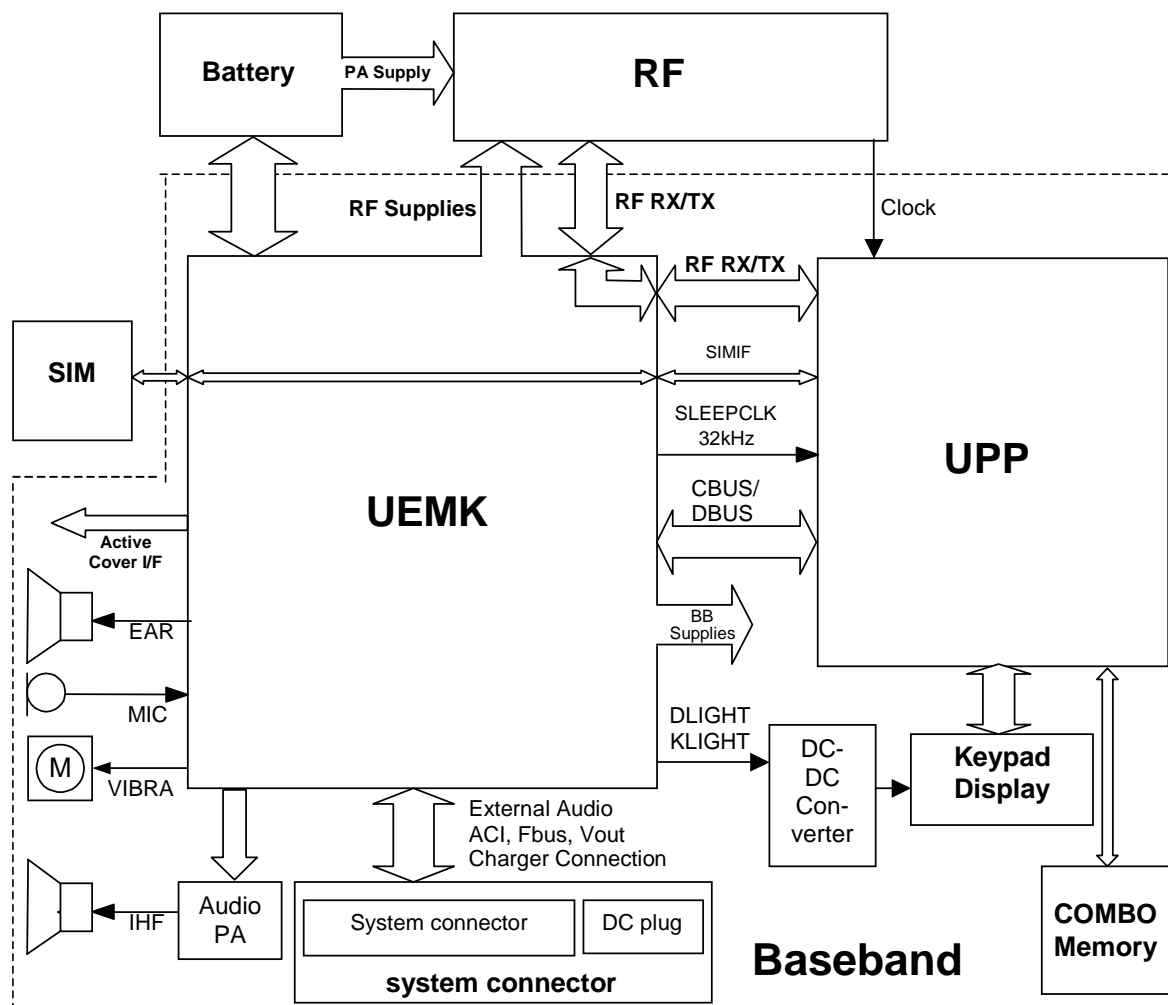

Figure 1: Baseband Block Diagram

RH-19 Baseband Feature List

Hardware characteristics:

- Single PWB design
- Universal Phone Processor UPP8Mv2.6 with 8Mbit internal SRAM
- Additional external 4Mbit SRAM and 64MBit FLASH memory in one single package (called Combo).
- Universal Energy Management ASIC "UEMK"
- GSM triple band (900/1800/1900 MHz)
- BL-5C/BL-5R battery
- Internal antenna assembled on IHF container
- Small SIM, supporting 1.8 & 3.0V
- Internal vibra motor

UI features:

- 130x130 pixel color display, 4096 colors
- Standard keypad with 4-way navigation key, two soft keys
- Illumination concept is based on a DC-DC converter
 - Display: two white LED's
 - Keypad: six white LED's
- Polyphonic ringing tones (MIDI)
- Internal hands-free
- Active Cover Connection

Environmental Specifications

Normal and Extreme Voltages

Following voltages are assumed as normal and extreme voltages for used battery:

- Nominal voltage: 3.7 V
- Lower extreme voltage: 3.2 V
- Higher extreme voltage (fast charging): 4.4 V

Temperature Conditions

Operational temperature range (all specifications met within this range)

-10°C..+55°C

Functional temperature range (Reduced performance) -30°C..+70°C

Storage temperature range: -30°C..+85°C

Humidity

Relative humidity range is 5.....95%.

The BB module is not protected against water. Condensed or splashed water may cause interim or permanent phone malfunction.

Any submerge of the phone most likely causes permanent damage.

Frequencies in Baseband

There are several clock frequencies at the baseband part. Below table lists all available frequencies. The asynchronous and diagnostic busses are not included.

Table 1: Frequency list

Frequency	Context	UPP	UEMK	Flash	SIM	Comment
52 MHz	Memory clock	X		X		MIN. FREQ.
26 MHz	RF clock	X				
13 MHz	DBUS, RFBusClk	X	X			
3.25 MHz	SIM		X		X	
Up to 1 MHz	RFConvClk	X	X			ESTIMATION
1 MHz	CBUS	X	X			
32 kHz	Sleep clock		X			Frequency depends on SW
1.2 kHz	ACI	X	X			
1.625 / 6.5	Display IF	X				

Printed Wire Board (PWB)

Characteristics of the PWB

- Single PWB
- 1.2 mm, 8 layer board
- Double sided assembled
- Through holes vias and buried vias are possible

The PWB is prepared for I-Line under filling of UEMK, UPP and the Flash (64 Mbit and 128 Mbit).

Baseband Architecture

Baseband Core

Universal Phone Processor (UPP)

Main characteristics of the used UPP are:

- DSP by Texas Instruments, LEAD3 PH2+ Megacell 16 bit DSP core, 32 bit I/F - max. speed 200 MHz.
- MCU based on ARM/Thumb 16/32 bit RISC MCU core - max. speed 50 MHz
- Internal 8 Mbit SRAM (PDRAM)
- General purpose USARTs
- SIM card interface
- Accessory interface (ACI)
- Interface control for: keypad, LCD, audio and UEMK control
- Handling of RF-BB interface

The UPP is housed in a 144-pin uBGA package (12x12mm, 0.8mm pitch).

In RH-19 the UPP is clocked by a 26MHz frequency from the RF-chip "Mjoelner".

This 26MHz-clock frequency is internally sliced down by UPP to 13MHz. This frequency is then inside UPP multiplied to different frequencies, e.g. 145MHz for the DSP core.

UPP can operate on 4 different voltages; 1.05, 1.3, 1.5 and 1.8V. The voltage can be programmed "on the fly" by the SW. For example in standby-mode, 1.3V is used for power saving, but in active-mode (i.e. call) the voltage is increased to 1.8V to get maximum performance.

Universal Energy Management (UEMK)

RH-19 uses the UEMK version so called "UEMK". UEMK is a die shrunk version of standard UEM's, but with the same functionality.

Main characteristics of UEMK's are:

- ACI support
- Audio codec
- 11 Channel A/D converter
- Auxiliary A/D converter
- Real time logic
- Baseband regulators
- RF regulators
- Voltage references needed for analogue blocks
- 32 kHz crystal oscillator
- SIM interface and drivers
- Security logic
- Storage of IMEI code
- Buzzer and vibra motor drivers
- 2 LED drivers
- Charging function
- RF interface converters

The UEMK is housed in a 168-pin uBGA package (12x12mm, 0.8mm pitch).

External Flash and External SRAM

The Combo-Memory is a multi chip package memory which combines 64Mbit (4Mx16) muxed burst multi bank Flash and 4Mbit muxed CMOS SRAM. These two dies are stacked on each other in one package. The functionality of the Flash memory is the same, as it is known from generic BB4.0 products.

The combo is supplied by single 1.8V for read, write and erase operation.

This Combo memory is housed in a 48-ball TBGA type with a 0.5mm ball pitch. The outer dimensions are 10x8mm and the thickness is 1.1 mm.

Energy Management

The energy management of RH-19 is based on BB 4.0 architecture. A so called semi fixed battery (BL-5C/BL-5R) supplies power primarily to UEMK ASIC and the RF PA. UEMK includes several regulators to supply RF and baseband. It provides the energy management including power up/down procedure.

Power Supply Modes

The functional behavior of the UEMK can be divided into 7 different states. Since the UEMK controls the regulated power distribution of the phone, each of these states affects the general functionality of the phone:

- No supply
- Backup
- Power off
- Reset
- Power on
- Sleep
- Protection

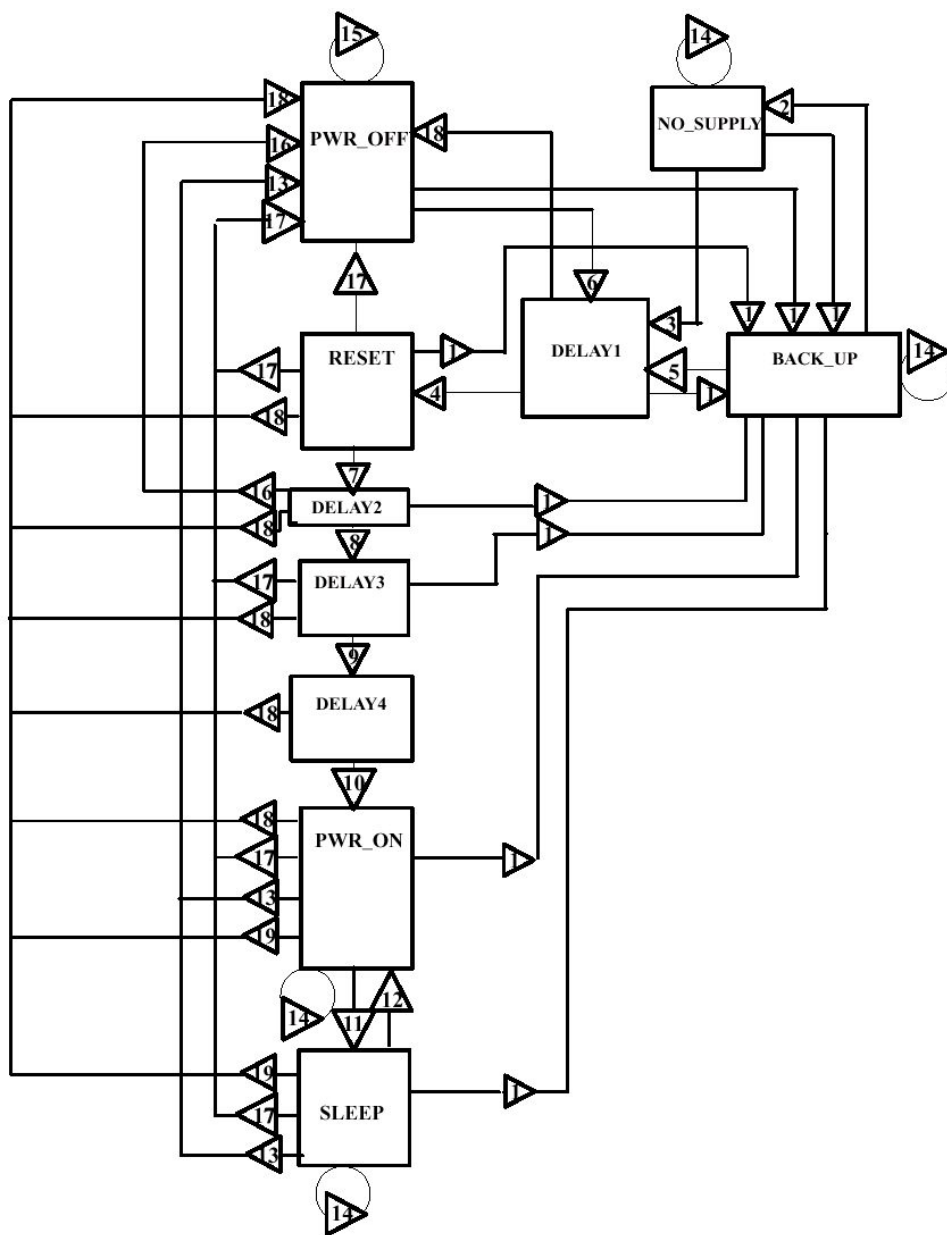

Figure 2 UEMK state diagram

The text below explains the state diagram. The symbol '↗' means that the voltage rises and '↘' that the voltage drops. '→' Means the result of the conditions set on the left most side.

$VBAT < V_{MSTR}$	and $VBACK > V_{BU_{COFF}}$	→ BACK_UP
$VBAT < V_{MSTR}$	and $VBACK < V_{BU_{COFF}}$	→ NO_SUPPLY
$VBAT \nearrow V_{MSTR+}$	and $VBACK < V_{BU_{COFF}}$	→ DELAY1
$VBAT > V_{MSTR}$	and DELAY1 elapses	→ RESET
$VBAT \nearrow V_{MSTR+}$	and $VBACK > V_{BU_{COFF}}$	→ DELAY1
$PWRONX = '0'$	or $VCHAR \nearrow VCHAR_{DET+}$ or $ALARM = '1'$	→ DELAY1
$VBAT > V_{COFF+}$		→ DELAY2
DELAY2 elapses		→ DELAY3
$VBAT > V_{COFF+}$	and DELAY3 elapses	→ DELAY4
DELAY4 elapses		→ PWR_ON
$SLEEPX = '0'$		→ SLEEP
$SLEEPX = '1'$		→ PWR_ON
$VBAT \searrow V_{COFF}$	and $VBAT > V_{MSTR-}$	→ PWR_OFF
No change		
$VBAT > V_{MSTR}$		→ Stay in PWR_OFF
$PWRONX \nearrow$ detection during DELAY2		→ PWR_OFF
Watchdog elapses (approx. 100 (μs))		→ PWR_OFF
Thermal shutdown		→ PWR_OFF
PwrKeyWatchdog (4 sec.) elapses		→ PWR_OFF

The different states of the UEMK are detailed in the sections below.

Note: RH-19 does not have a backup battery.

No Supply

In the NO_SUPPLY mode the UEMK has no supply voltage ($VBAT < V_{MSTR}$ and $VBACK < V_{BU_{COFF-}}$). This mode is due to the fact that both the main battery is either disconnected or discharged to a low voltage level.

The UEMK will recover from NO_SUPPLY into RESET mode if the VBAT voltage level rises above the V_{MSTR+} level by either reconnecting the main battery or charge it to such level.

Backup

In BACK_UP mode the main battery is either disconnected or has a low voltage level ($VBAT < V_{MSTR-}$ and $VBACK > V_{BU_{COFF+}}$).

The regulator VRTC that supplies the real time clock is disabled in BACK_UP mode. Instead the unregulated backup battery voltage VBACK supplies the output of the VRTC. All other regulators are disabled and the phone has no functionality.

The UEMK will recover from BACK_UP mode into RESET mode if VBAT rises above V_{MSTR+} .

Power Off

In order for the UEMK to be in PWR_OFF mode, it must have supply voltage ($V_{BAT} > V_{MSTR+}$).

The regulator VRTC regulator is enabled and supplying the RTC within the UEMK. The UEMK will enter RESET mode after a 20 ms delay whenever one of the below listed conditions is logically true:

- The power button is activated
- Charger connection is detected
- RTC alarm is detected

The UEMK will enter PWR_OFF from all other modes except NO_SUPPLY and BACK_UP if the internal watchdog elapses.

Reset

When the UEMK enters RESET mode from PWR_OFF mode the watchdog is enabled. If the VBAT fails to rise above the power-up voltage level V_{COFF+} (3.1 V) before the watchdog elapses, the UEMK will enter PWR_OFF mode. Otherwise after a 200 ms delay the regulator VFLASH1 will be enabled and after an additional delay of 500 μ s the regulators VANA, VIO, VCORE and VR3 will be enabled. All other regulators i.e. VFLASH2, VSIM, VR1, VR2 and VR4 - VR7 are software controlled and disabled by default. After an additional delay of 20 ms the UEMK enters PWR_ON mode.

Power On

In PWR_ON the UEMK is fully functional in the sense that all internal circuits is powered up or can be by means of software. The UEMK will enter PWR_OFF mode if VBAT drops below V_{COFF-} for a period of time longer than 5 μ s. The UEMK will furthermore enter PWR_OFF mode if either of the watchdogs Operational State Machine (approx. 100 μ s), Security (32 sec.) or Power Key (4 sec.) elapses or if any of the regulators triggers the thermal protection circuitry

Sleep

The UEMK can be forced into SLEEP mode by the UPP by setting the input SLEEPX low for more than 60 μ s. This state is entered when the external UPP activity is low (phone in sleep) and thereby lowering the internal current consumption of the UEMK. The regulator VANA is disabled and VR1 - VR7 are either disabled or in low quiescent mode.

From SLEEP the UEMK enters PWR_ON if SLEEPX goes high, PWR_OFF mode if watchdog elapses or BACK_UP mode if VBAT drops below V_{MSTR-} .

Protection Mode

The UEMK has two separate protection limits for over temperature conditions, one for the charging switch and one for the regulators. The temperature circuitry measures the

on-chip temperature. In case of charging over temperature, the circuit turns the charging switch off. In case of over temperature in any of the regulators, the UEMK powers off.

Battery BL-5C/BL-5R

Product RH-19 uses the so called "case-less" Li Ion battery BL-5C/BL-5R.

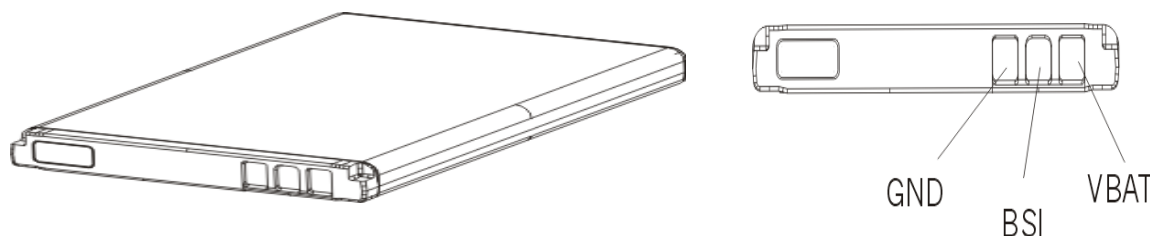

Type	Capacity	Manufacturer	BSI Value
BL-5C	850 mAh	Many sources	75 kOhm
BL-5R	820mAh	Sanyo	75 kOhm
BL-5R	820mAh	Matsushita	47 kOhm

Main advantage of case-less battery types is the overall size, particular the thickness and the number of contact terminals.

These batteries have a three-pin connector (BTEMP is not used). The battery does not support temperature measurement inside battery pack. In order to get temperature information of the battery, a NTC is mounted on the PWB within the BB area.

Ni based batteries are not supported by RH-19.

Power Distribution

Under normal conditions, the battery powers the baseband module. Individual regulators located within the UEMK regulate the battery voltage **VBAT**. These regulators supply the different parts of the phone. 8 regulators are dedicated to the RF module of the phone, and 6 to the baseband module.

The **VSIM** regulator is able to deliver both 1.8V and 3.0V DC and thus supporting two different SIM technologies. A register internally in the UEMK controls the output of VSIM and can be written to by the MCU via the CBUS.

The regulator **VCORE** is likewise adjustable and controlled by registers written by the MCU. VCORE supplies the core of the UPP and can be adjusted on the fly by the MCU if DSP capacity is inadequate. Higher VCORE supply (1.8 V) results in faster core operations in the UPP.

The regulator **VFLASH2** supplies audio circuitry and is controlled by the MCU

Regulators **VANA**, **VFLASH1** and **VIO** are solely controlled by the UEMK and cannot be

enabled or disabled by the MCU. Furthermore, VFLASH1 and VIO are both ON, though in low quiescent mode when phone is in sleep mode. An output current of 500 μ A can be drawn from the regulators. VIO supplies the UPP, FLASH and LCD, VFLASH1 supplies the LCD module, VANA is supplying analogue parts internally in the UEMK as well as the baseband audio circuitry and pull-up resistors on the input of the UEMK slow AD converters.

System connector provides a voltage to supply accessories. The white LED's need a higher voltage supply as the battery can provide in bad condition. Separate external regulators supply both consumers.

The regulators **VR1A, VR1B, VR2 - VR7** and **IPA1 - IPA4** are controlled by the DSP via the DBus. VR4 - VR7 are controlled by the UEMK as well and are disabled in sleep regardless of DSP writings.

VBAT is furthermore distributed, unregulated, to the RF power amplifier, audio power amplifier and external baseband regulators.

The CHACON module in the UEMK controls the charging of the main battery. Furthermore it contains a 3.2 Vdc regulator for charging of the backup battery and a 1.8 Vdc regulator supplying the internal real time clock.

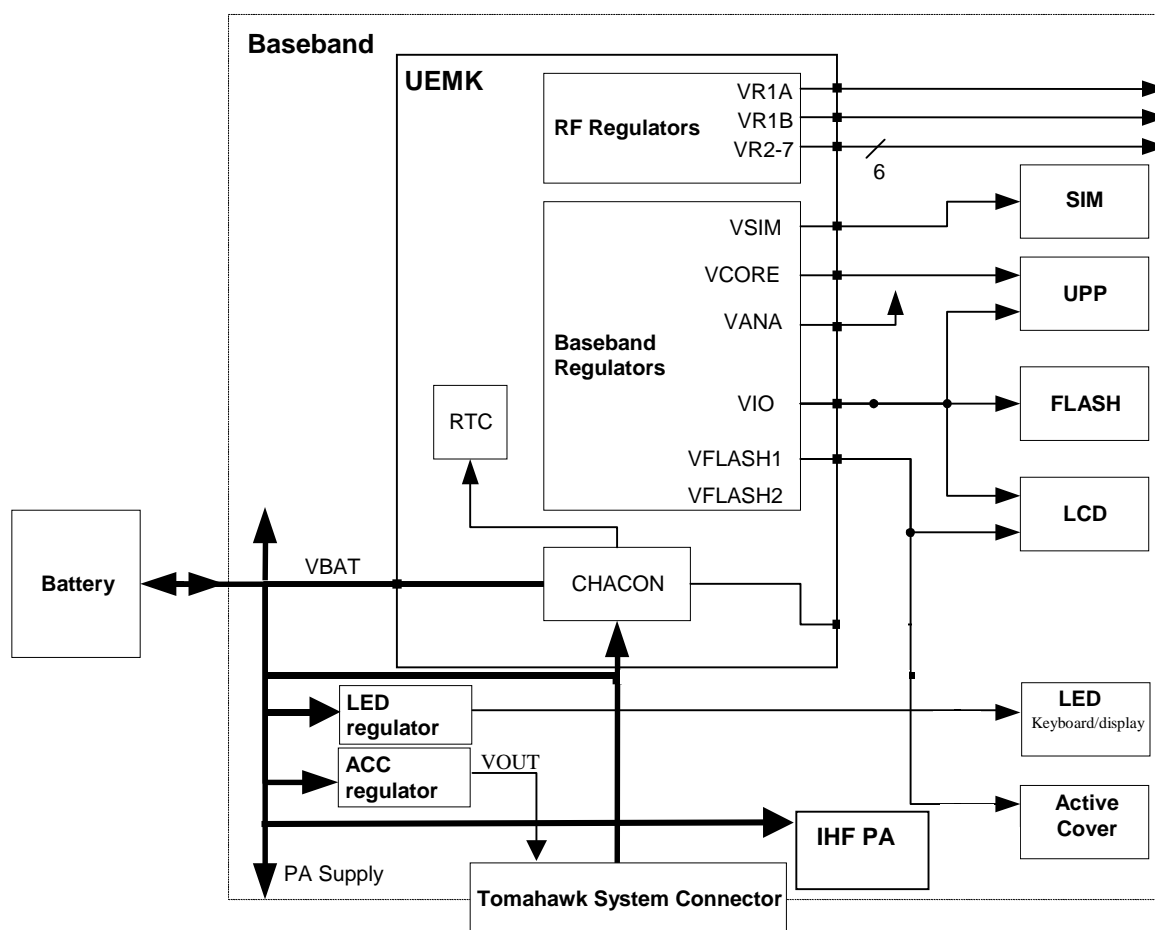

Figure 3: Baseband power distribution

DC Characteristics

The following table reflects the specifications of voltage and current regulators within the UEMK:

Table 2: UEMK regulator outputs

Regulator	Target	Output Voltage (V)			Output Current (mA)	
		Min	Typ	Max	Min	Max
VR1A	RF	4.6	4.75	4.9	0	10
VR2 ⁴	RF	2.70	2.78	2.86	0.1	100
VR3	RF	2.70	2.78	2.86	0.1	20
VR4	RF	2.70	2.78	2.86	0.1	50 0.1
VR5, VR6 ¹	RF	2.70	2.78	2.86	0.1	50 0.1
VR7	RF	2.70	2.78	2.86	0.1	45
VrefRF01	RF	1.334	1.35	1.366	-	0.1
VIO ¹	BB	1.72	1.8	1.88	0.005 0.005	150 0.500
VSIM ²	BB	1.745 2.91	1.8 3.0	1.855 3.09	0.005 0.005	25 0.500
VANA	BB	2.70	2.78	2.86	0.005	80
VCORE ²	BB	1.000	1.053	1.106	0.005	70
		1.235	1.3	1.365	0.005	85
		1.425	1.5	1.575	0.005	100
		1.710	1.8	1.890	0.005	120
		0.974	1.053	1.132	70	200
		1.215	1.3	1.365	85	200
		1.410	1.5	1.575	100	200
		1.692	1.8	1.890	120	200
VFLASH1	BB	2.70	2.78	2.86	0.005 0.005	70 1.5
VFLASH2 ³	BB	2.70	2.78	2.86	0.005	40

- 1 The second current value indicates the maximum possible output current of the regulator when in low quiescent mode.
- 2 The output voltages are split into two different current categories. The upper part is the lower range of output current, and the lower part is the higher range of output current.
- 3 Condition in sleep-mode depends on MCU writings to UEMK regulator register solely.
- 4 Condition in sleep-mode depends on DSP writings to UEMK register.

Charging

The charging of the main battery is controlled by the UEMK. External components are needed in order to sense charging current and voltage that are needed by the Energy Management (EM) software and to protect against EMC into the baseband area. The charger is connected to the phone via the DCT3 bottom connector or the charger pads of the Pop-port system connector.

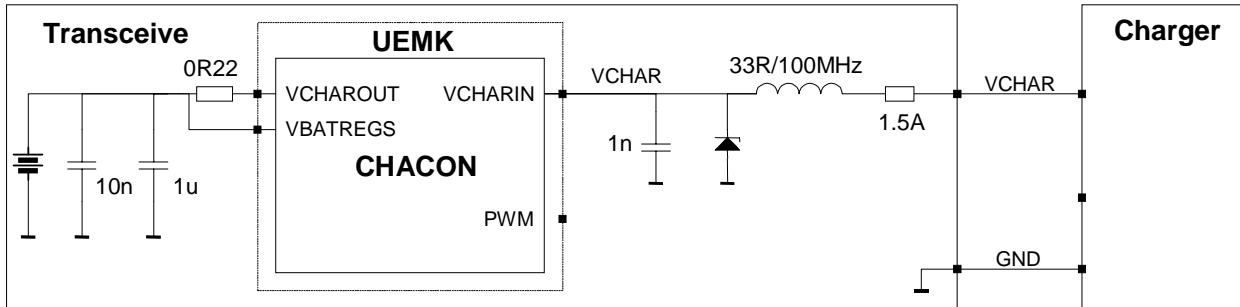

Figure 4: Charging configuration

Connecting a charger to the telephone creates a voltage, VCH, on the UEMK VCHAR input. When the VCH level is detected to rise above the VCH_{DET} threshold (2.0 Vdc) by CHACON, charging starts.

3-wire chargers can be connected, but the PWM is not supported.

In order to protect the phone from damage due to over voltage caused by a sudden battery removal while charging proceeds, the charger switch is closed immediately.

Audio Circuitry

This section describes the audio-HW inside the BB. Thus e.g. external audio components and acoustics are not considered with the details in this section.

The main topology comes from other phones using BB4.0 engine, where the audio-HW is mostly integrated into the UEMK-ASIC. The biggest difference is that RH-19 has also integrated hands-free (IHF).

Audio Block Diagram

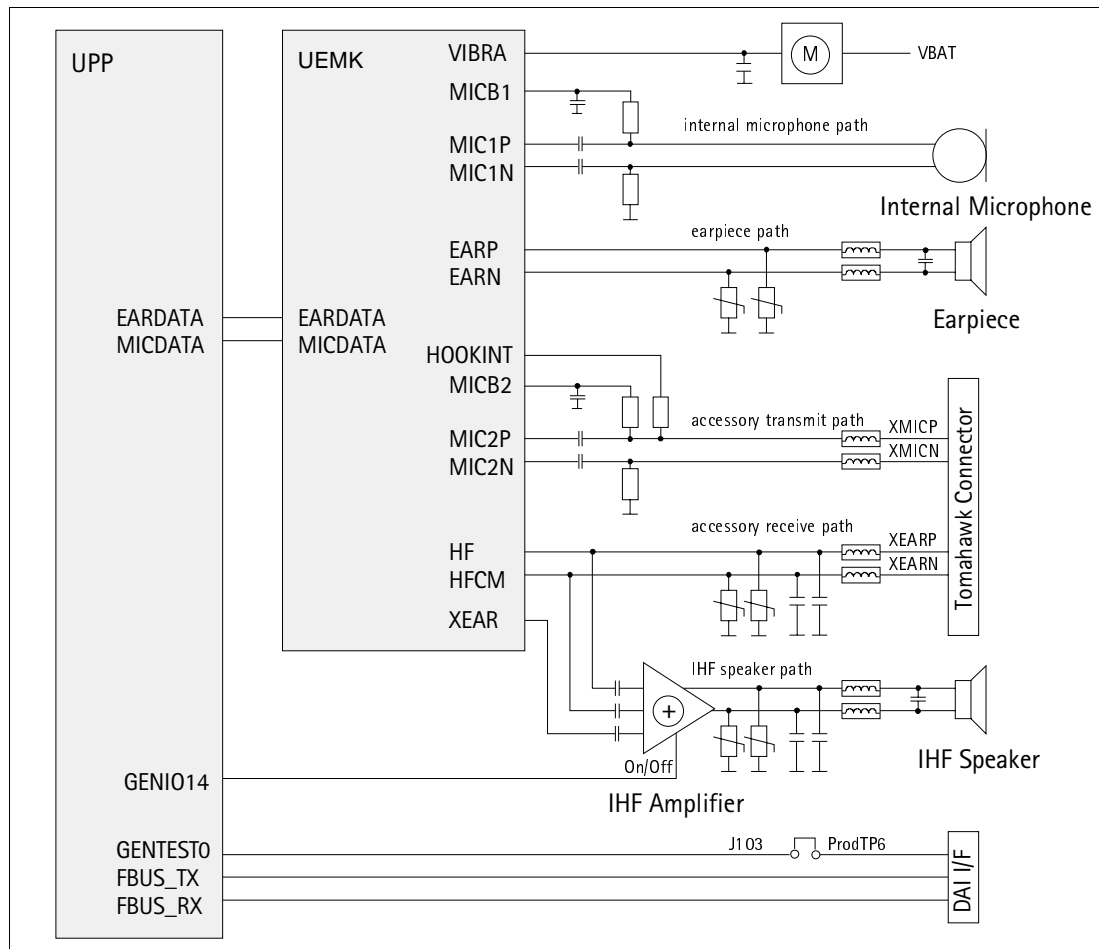

Figure 5: Audio Block Diagram

Earpiece

RH-19 uses an earpiece which is also referred to as "PICO speaker". This is a 32 ohm speaker with the diameter of 8 mm.

Earpiece is fed by the differential signals "EARP" & "EARN" from UEMK. The signals run quite directly from UEMK to the earpiece, only some passive and EMC protection components are needed.

The external earpiece signals are fed by the "HF" & "HFCM" pins.

The level (swing) of earpiece-signals can be adjusted by register values inside UEMK. These signals have common voltage level of 1.35 V (0.8 V for HF) at UEMK pins.

Microphones

An EMC-improved type of microphone is used as internal microphone in RH-19, diameter of which is 2.2mm.

Internal Microphone circuitry is driven single ended. Microphone needs bias voltage,

which is provided by UEMK and is fed through a resistor to the microphone. A resistor is also needed to the other side of the microphone, i.e. between microphone and GND, in order to provide the differential signals to UEMK. Audio signals are AC-coupled from the microphone.

For the external microphone a differential input is used.

MIC1N & MIC1P (audio signals) and MICB1 (bias voltage) are used for the internal microphone. MIC2N & MIC2P and MICB2 are used for external microphone.

Integrated Hands-free (IHF)

The speaker used for IHF is a 16 mm diameter speaker with 8 Ohm impedance, and is also known as "MALT" speaker.

IHF circuitry uses differential outputs from UEMK.

Depending on the audio mode the IHF amplifier is driven either from UEMK HF / HFCM or XEAR audio outputs. The IHF audio power amplifier (APA) LM4890 has a bridge-tied-load (BTL) output in order to get the maximum use of supply voltage. The supply voltage for driving circuitry of speaker is VBAT, thus the swing across the speaker is \pm VBAT.

The shutdown of the IHF PA is controlled by UPP using GENIO14.

Audio Accessory Receive Path

In RH-19 the accessory receive path is directly driven from UEMK HF / HFCM differential audio outputs, the output signal complies with the Pop-port accessory interface.

For EMC protection ferrites are connected in series to the earpiece, for ESD protection varistors are used.

Audio Control Signals

Furthermore, a couple of signals are needed to control the external audio device.

The HEADINT signal is needed for recognizing the external device (e.g. headset) connected to the system. The recognition is based on the ACI-pin on the system connector, which is shorted to ground inside the external device.

The button of the external device generates HOOKINT. This is used e.g. to answer or to end a phone call.

Acoustics

Earpiece Acoustic

RH-19 uses the so called "PICO" earpiece.

This earpiece is mounted into the UI-shield assembly, the sealing of the back and front volume are implemented in the UI-shield by die casting. This sealing part also provides

the sealing against the A-cover.

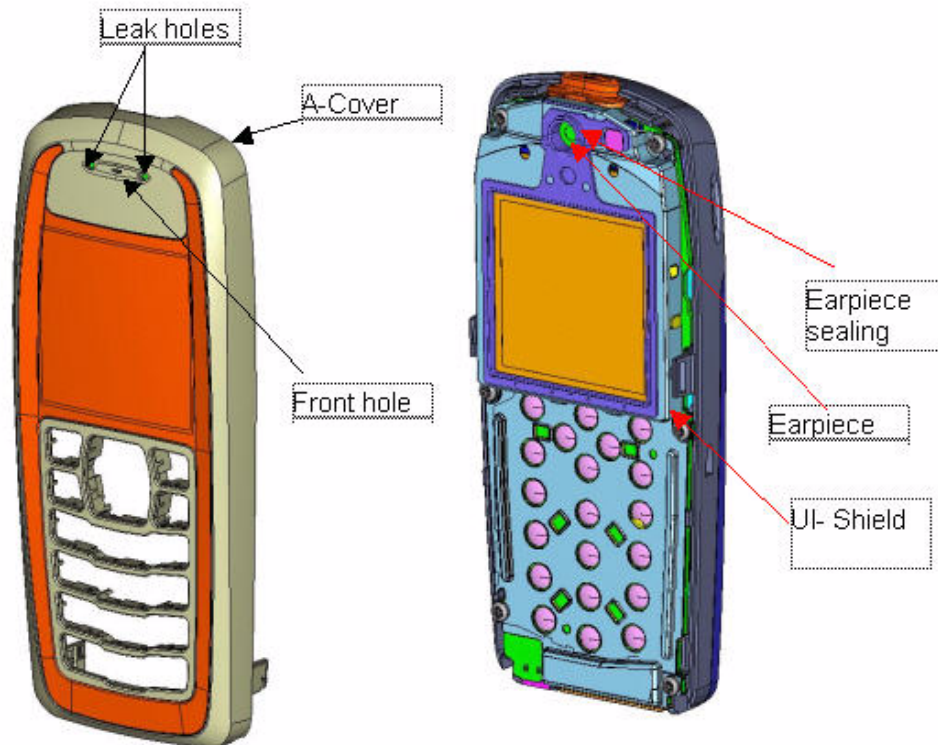

Figure 6: Earpiece implementation

IHF Speaker Acoustics

As mentioned, the so called "MALT" speaker is used in RH-19 for integrated hands-free and ringing tone applications.

The IHF speaker is mounted to the IHF enclosure by means of the speaker adhesive. The IHF enclosure provides the needed back volume for the speaker. The IHF enclosure is closed with the IHF lid, which is carrying the IHF pins to contact the IHF speaker.

The sealing of the effective acoustic volumes is achieved with the enclosure adhesive, which glues the IHF lid to the IHF enclosure.

To provide a long-term reliability additionally the IHF lid is heat stacked to the IHF enclosure.

The B-cover gasket provides a fitting between the B-cover and the IHF enclosure. This fitting is attached with an adhesive to the IHF enclosure and also includes a dust and water shield to protect the speaker inside from dust and swarf.

Due to the fact that the IHF enclosure is also carrying the antenna radiator, the whole assembly is named antenna assembly.

Due to heat stacking of the antenna assembly, it cannot be disassembled and in case of failure only be exchanged as one complete assembly.

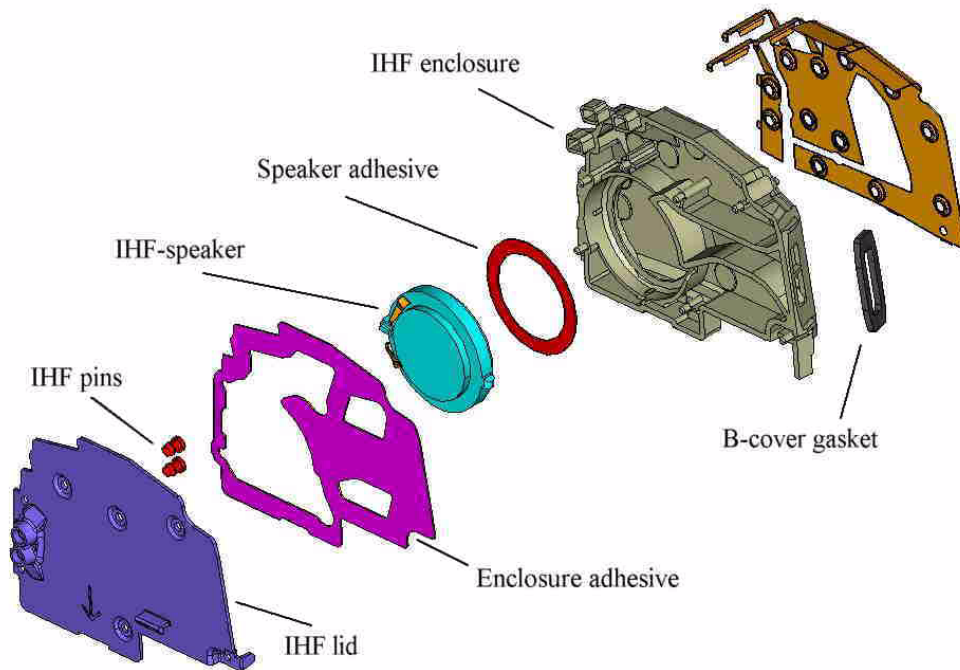

Figure 7: Exploded View of Antenna Assembly

Microphone Acoustics

A standard microphone module is used. This module is embedded into a so called "rubber boot" and connected to RH-19 system module by spring contacts.

The microphone is placed close to the system connector. The sound port of the microphone is located towards the bottom of the phone

Vibra Motor

A vibrating alerting device is used to generate a vibration signal for an incoming call.

This vibra is located in the bottom section of the phone.

The vibrator is driven by the UEMK output VIBRA, and controlled with a PWM signal. The supply of the vibra is taken from the battery voltage of the phone.

Audio Modes

There are six different audio configurations. These can create following audio modes:

- Hand portable
- Integrated hands-free
- Headset
- Loop set
- External hands-free

The following audio sources have to be routed according to the active audio mode:

- Speech

- Ringing tones / SMS tones
- Keypad tones
- Error tones / Warning tones
- Game tones

Hand Portable Mode

In hand portable mode earpiece path and internal microphone path are in use. The audio sources are routed according to the following table:

Table 3: Handportable mode audio routing

Audio Source	Earpiece	Internal Microphone	IHF speaker	Accessory receive path	Accessory transmit path
Speech	X	X			
Ringing tones, SMS tones			X		
Keypad tones	X				
Warning / Error tones			X		
Game tones			X		

Integrated Hands-free Audio Mode

In integrated hands-free mode IHF path and internal microphone path are used. The audio sources are routed according to the following table:

Table 4: IHF mode audio routing

Audio Source	Earpiece	Internal Microphone	IHF speaker	Accessory receive path	Accessory transmit path
Speech		X	X		
Ringing tones, SMS tones			X		
Keypad tones			X		
Warning / Error tones			X		
Game tones			X		

Headset Audio Mode

In headset mode accessory receive path and accessory transmit path are used. RH-19 supports the following headsets:

- HDB-4: Mono Headset, boom design
- HS-1C: Camera Headset
- HS-10: Retractable Headset
- HSU-3: Privacy Headset

The audio sources are routed according to the following table:

Table 5: Headset mode audio routing

Audio Source	Earpiece	Internal Microphone	IHF speaker	Accessory receive path	Accessory transmit path
Speech				X	X
Ringing tones, SMS tones			X	X	

Table 5: Headset mode audio routing

Audio Source	Earpiece	Internal Microphone	IHF speaker	Accessory receive path	Accessory transmit path
Keypad tones				X	
Warning / Error tones				X	
Game tones				X	

Loop set Audio Mode

In loop set mode accessory receive path and accessory transmit path are used. RH-19 supports the loop set LPS4.:

Table 6: Loop set mode audio routing

Audio Source	Earpiece	Internal Microphone	IHF speaker	Accessory receive path	Accessory transmit path
Speech				X	X
Ringing tones, SMS tones			X		X
Keypad tones				X	
Warning / Error tones				X	
Game tones				X	

External Hands-free Audio Mode

In external hands-free mode accessory receive path and accessory transmit path are used. RH-19 supports external hands-free accessories:

- BHF-1: basic car hands-free kit
- HFU-4: advanced car hands-free kit

Table 7: External hands-free mode audio routing

Audio Source	Earpiece	Internal Microphone	IHF speaker	Accessory receive path	Accessory transmit path
Speech				X	X
Ringing tones, SMS tones				X	
Keypad tones				X	
Warning / Error tones				X	
Game tones				X	

User Interface

LCD module

RH-19 is using a 130 * 130 dot LCD display with 4096 colors. The illumination is integrated into the LCD module.

Baseband-LCD interface

The LCD display is connected to the transceiver PWB by 10-pin board-to-board connector.

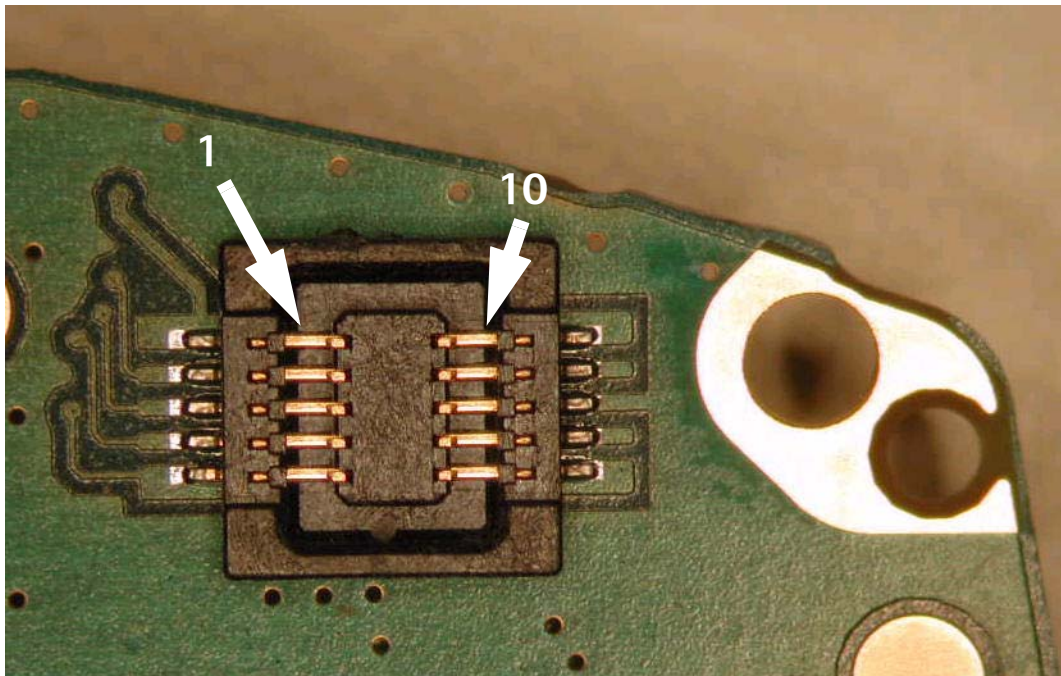

Figure 8: LCD connector

DC Characteristics

Display is using 3-wire serial interface. Signals for LCD panel are shown in table below.

The chip-select **XCS** (active low) enables and disables the serial interface. **RESX** (active low) is external reset signal. The **SCL** is serial data clock. **SI** data-length is 8 bits + **D/C**-bit. First bit is **D/C**-bit which indicates the status of following 8 bit data. In case of command data **D/C**-bit is low ('0'). **VDDI** is logic voltage supply for the display. **VDD** is supply voltage for high voltage generation. **GND** is system ground for display.

Table 8: LCD Interface DC Characteristics

Pin No	Signal name	Description	Min	Typical	Max	Unit	Description
1	VDDI	IN	1.7	1.8	VDD	V	Logic voltage supply
2	RESX	IN	H: 0.7xVDD L: 0		H: VDDI L: 0.3xVDDI	V	Reset (active low)
3	SI	IN	H: 0.7xVDDI L: 0		H: VDDI L: 0.3xVDDI	V	Serial input
4	SCL	IN	H: 0.7xVDDI L: 0		H: VDDI L: 0.3xVDDI	V	Serial input clock
					6.5	MHz	Serial data clock speed
5	XCS	IN	H: 0.7xVDDI L: 0		H: VDDI L: 0.3xVDDI	V	Chip select (Active low)
6	VDD	IN	2.6	2.75	3.6	V	Voltage supply
7	NC			0		V	Not connected
8	GND						System ground
9	LED -		0.505	0.525	0.545	V	

Table 8: LCD Interface DC Characteristics

Pin No	Signal name	Description	Min	Typical	Max	Unit	Description
10	LED +		TBD	7.0	TBD	V	

(Note: H stands for high signal level and L for low signal level.)

Current Consumption

Table 9: LCD Interface Current Consumption

Pin No.	Signal name	Description	Min	Typical	Max	Unit	Description
6/8	VDD	Display pixels	-	0.5	1.25	mA	Full mode, 4 k colors. Maximum for chess pattern picture.
6/8	VDD	Display pixels	-	0.15	0.25	mA	Partial mode, 32 lines, 4 k colors. Maximum for chess pattern picture
9/10	LED - LED +	Display illumination	-	15	30	mA	2 white LED in series

Maximum Ratings

Table 10: LCD Interface Maximum Ratings

Item	Symbol	Rating	Unit
Power Supply voltage	V_{DD}	-0.3 to + 4.0	V
Power supply voltage (logic)	V_{DDI}	-0.3 to + 4.0	V
Signal Input voltage	V_{IN}	-0.3 to $V_{DDI} + 0.5$	V
LED input current	I_{LED}	30	mA

AC Characteristics

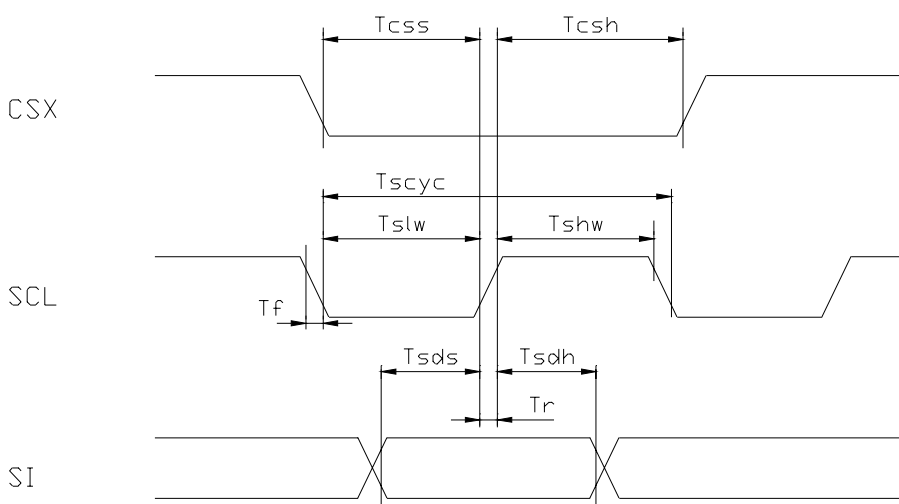

Figure 9: Write characteristics

Table 11: AC characteristics

Signal	Symbol	Parameter	Min	Max	Unit
CSX	T_{CSS}	Chip select setup time	10	-	ns
	T_{CSH}	Chip select hold time	35	-	ns
SCL	t_{SCYC}	Clock cycle	150	-	ns
	t_{SLW}	Clock pulse "L" duration	60	-	ns
	t_{SHW}	Clock pulse "H" duration	60	-	ns
SI	T_{SDS}	Data setup time	60	-	ns
	T_{SDH}	Data hold time	60	-	ns

1. Rise t_r and fall t_f time must be within 15 ns maximum.
2. Timings are specified according to 30% and 70% of V_{DD1} as reference. Definitions to rise and fall times are described in the figure below.

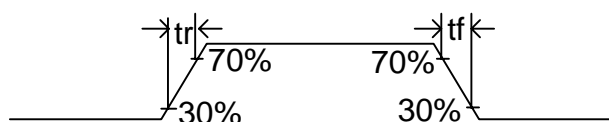

Figure 10: Rise and fall time in input and output

Table 12: Rise and fall times in input and output of display driver

Parameter	Symbol	Min	Max	Unit
Input	T_r, t_f		15	ns
Output	T_r, t_f		15	ns

Reset Timing

Reset timing characteristics are shown in the figure below.

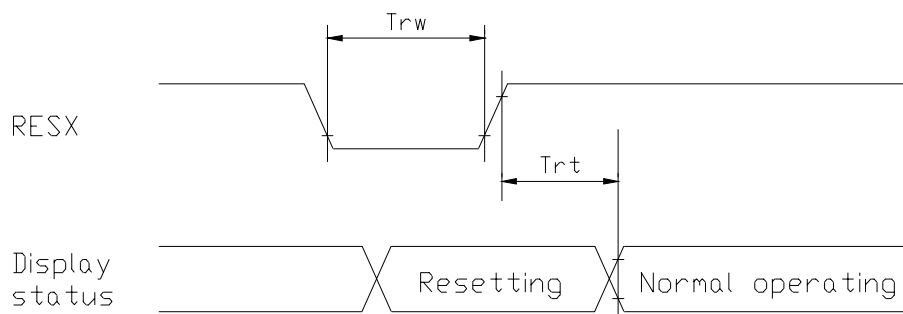

Figure 11: Reset timing

Table 13: Reset Timing

Signal	Symbol	Parameter	Min	Max	Unit
RESX	tRW	Reset pulse duration	200		ns
	tRT	Reset cancel		1500	ns

Display Power On/Off Sequence

Power on/off sequence if described in the figure below

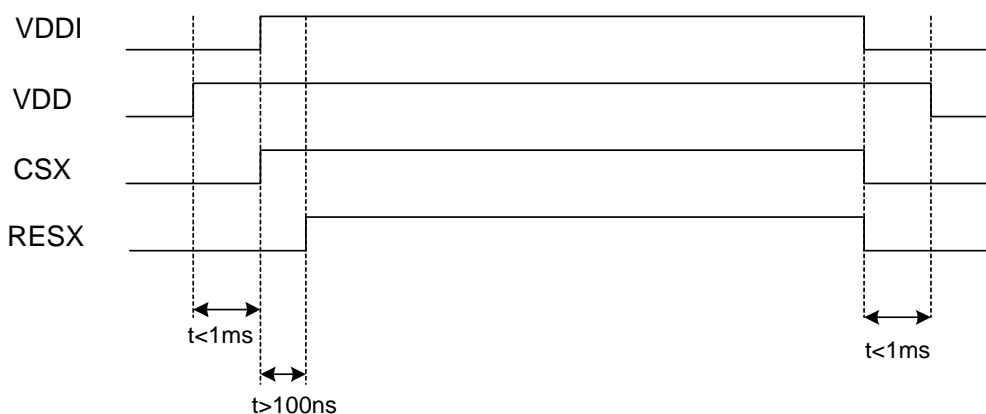
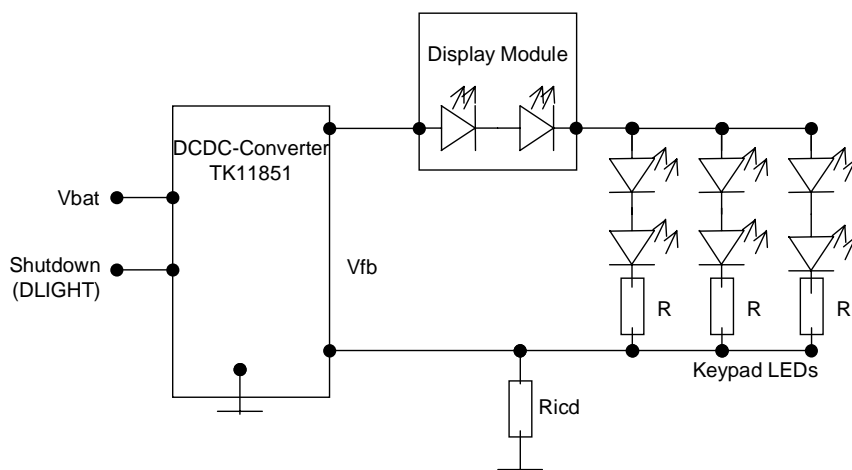

Figure 12: Power on/off Sequence

LED Power Supply

In RH-19, white LED are used for LCD and for keypad lighting. Two LED are used for LCD lighting and six LED for keyboard. A step up DC-DC converter TK11851 is used as a LED driver.



The display LEDs are driven in serial mode to achieve stable backlight quality. This means constant current flow through LCD LEDs. Serial resistance R_{lcd} is used to define the proper current. The feedback signal, FB, is used to control the current. Driver will increase or decrease the output voltage for LEDs to keep the current stable.

Keyboard LED are driven in 2 serial/3 parallel mode. This means constant current flow through each branch. Serial resistance R are used to limit the current through LEDs.

Driver is controlled by the UEMK via the DLIGHT open drain output (internal pull up active). This signal is connected to driver EN-pin. It is possible to control the LED brightness by PWM.

Keypad

The RH-19 phone doesn't have separate keyboard PCB. The keys are directly connected via the KEYB(10:0) bus to the UPP. The keypad consist of a 5x4 matrix, meaning 5 rows (ROW0 - ROW4) and 4 columns (COL1 - COL4).

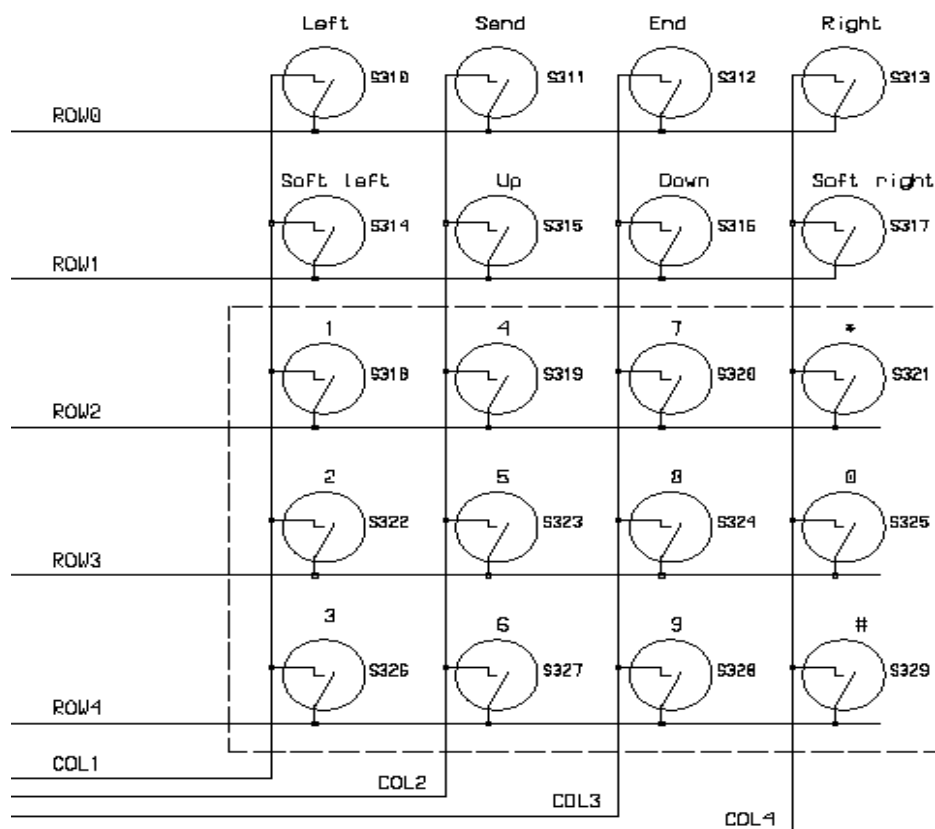

Figure 13: RH-19 keypad

Within the RH-19 design, there was a requirement to allow the use of multiple keys to be operated at a time, for use with games etc. Thus the keypad can be operated in this manner.

The power on key is connected to the UEMK PWRONX signal.

SIM Interface

RH-19 uses the same SIM-card reader (SIM reader) as the NPL-2. Electrical connection of SIM reader is similar to other DCT4 products.

The SIM interface is split between UEMK and UPP (see figure below). This has been done in order to reduce the amount of interconnections on the SIM interface between the UPP and the UEMK.

The SIM interface control logic and UART is integrated into the UPP. The SIM interface start-up and power down sequence, including timing and reset generation is implemented in UEMK. The SIM interface in the UPP supports the SIM speed enhancement features, which improves the data transfer rate in the SIM interface.

The UEMK contains the SIM interface logic level shifting. UPP SIM interface logic levels are 1.8V. The SIM interface can be programmed to support 3V and 1.8V SIMs. A 5V SIM interface is not supported. A register in the UEMK selects the SIM supply voltage. It is only allowed to change the SIM supply voltage when the SIM IF is powered down.

The SIM power up/down sequence is generated in the UEMK. The Battery Size Indication (BSI) is used to recognize if the battery suddenly is removed from the transceiver block. The SIMCardDet is not used. If the BSI goes low, the power down sequence is automatic initiated. The SIMIF will then force all the connections low, i.e. SIMRST, SIMCLK, SIM-DATA and VSIM. A comparator inside the UEMK does the monitoring of the BSI signal. The comparator offset is such that the comparator output does not alter state as long as the battery is connected. The BSI comparator threshold level is 2.1 V with 75 mV hysteresis.

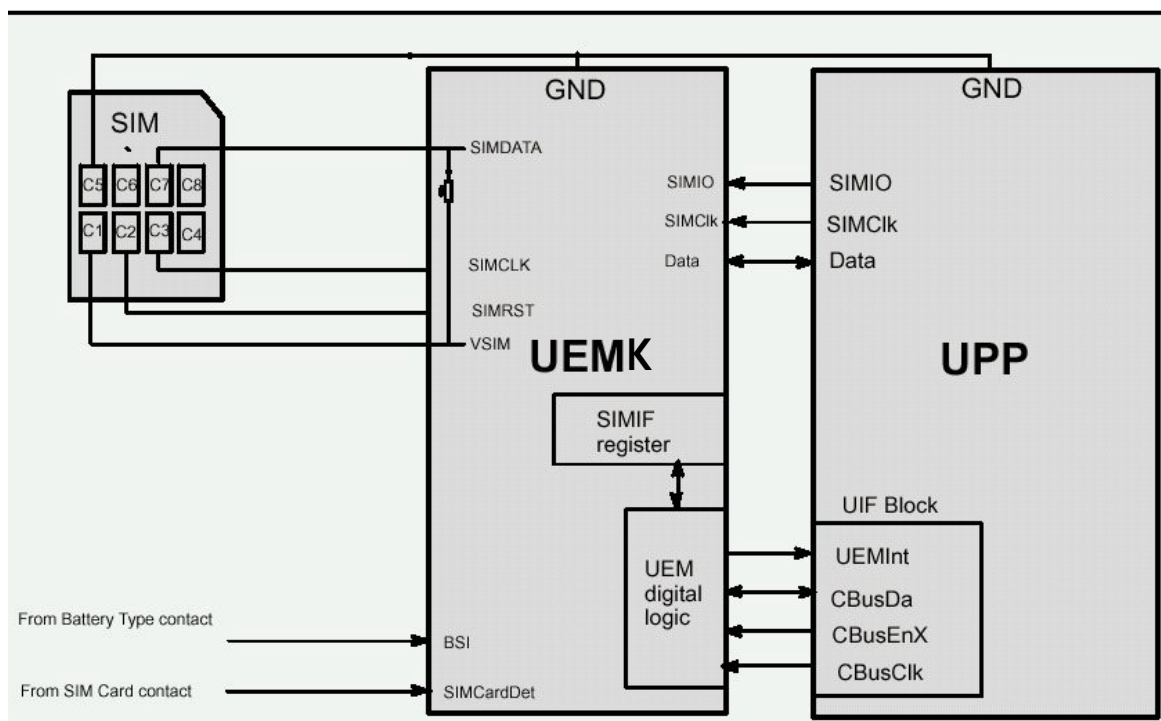

Figure 14: UPP, UEMK and SIM Connections

BB-RF Interface

The below table describes all the signals from the baseband block to the RF block and back. The signal names are based on the schematics.

Digital Signals between BB and RF

For the digital interfaces UPP and Mjoelner use only level shifting IO. Level shifters of both are supplied with VIO from UEMK. VIO limits are specified in chapter 5.3 and have been used to calculate the limits below (because $V_{IO_{min}}$ is 1.72V this was used for UPP $V_{DD_{Smin}}$ and not the limit from UPP which would have been 1.26V).

Values are referenced to GND unless otherwise specified.

Table 14: RF-BB Interface Digital Signals

Signal name	From	To	Parameter		Min	Typ	Max	Unit	Notes
RFICCTRL (2:0)			Mjoelner control bus						
RFBUSEN1 RFICCTRL(2)	UPP RFBUSEN1X	Mjoelner RFBUSENX	Logic "1"	Mjoelner input	1.22			V	RF Chip select. Active Low
				UPP output	1.37		1.88	V	
			Logic "0"	Mjoelner input	0		0.4	V	
				UPP output	0		0.40	V	
RFBUSDA RFICCTRL(1)	UPP RFBUSDA	Mjoelner RFBUSDA	Logic "1"	Mjoelner input	1.22			V	RF serial data. (bi-directional)
				UPP output	1.37		1.88	V	
				Mjoelner output	1.32			V	
				UPP input	1.32		1.88	V	
			Logic "0"	Mjoelner input	0		0.4	V	RF serial data. (bi-directional)
		UPP output		0		0.40	V		
		Mjoelner output		0		0.4	V		
		UPP input		0		0.51	V		
RFBUSCLK RFICCTRL(0)	UPP RFBUSCLK	Mjoelner RFBUSCLK	Logic "1"	Mjoelner input	1.22			V	RF bus clock.
				UPP output	1.37		1.88	V	
			Logic "0"	Mjoelner input	0		0.4	V	
				UPP output	0		0.40	V	
			Clock Speed			13		MHz	
GENIO (28:0)			General purpose I/O						
TXP GENIO(5)	UPP GENIO5	Mjoelner TXP	Logic "1"	Mjoelner input	1.22			V	Transmitter power control enable.
				UPP output	1.37		1.88	V	
			Logic "0"	Mjoelner input	0		0.4	V	
				UPP output	0		0.40	V	
RESET GENIO(6)	UPP GENIO6	Mjoelner RESET	Logic "1"	Mjoelner input	1.22			V	Reset to RF chip. Active low.
				UPP output	1.37		1.88	V	
			Logic "0"	Mjoelner input	0		0.4	V	
				UPP output	0		0.40	V	

Analog Signals between BB and RF

The values indicated in the table below are input requirements of the device in the "to column" when nothing else is stated. Values are referenced to GND unless otherwise specified.

Table 15: RF-BB-Interface Analog Signals

Signal name	From	To	Parameter	Min	Typ	Max	Unit	Notes
Clock			System clock for phone					
RFCLK	Mjoelner REFOUT	UPP RFCLK	Frequency		26		MHz	System clock
				-20		+20	ppm	
			Duty cycle	40		60	%	
			Signal amplitude	0.3		1.32	Vpp	Upp input req.
			Setling time			5.0	ms	VR3 on to stable clock @ UPP input
RFCONV (9:0)			RF / BB analogue signals					
RXIINP RFCONV(0)	Mjoelner RXIP	UEMK RXIINP	Max input Voltage swing	1.35	1.4	1.45	Vpp	Differential complex RX BB signal
RXIINN RFCONV(1)	Mjoelner RXIM	UEMK RXIINN	Nominal Voltage swing				V	
RXQINP RFCONV(2)	Mjoelner RXQP	UEMK RXQINP	Input DC level	1.3	1.35	1.4	Vdc	
RXQINN RFCONV(3)	Mjoelner RXQM	UEMK RXQINN	Signal frequency		67,7		KHz	
			Input BW			270.83	KHz	
TXIOUTP RFCONV(4)	UEMK TXIOUTP	Mjoelner TXIP	Max Differential output swing (ref. TxIN)	2.15	2.2	2.25	Vpp	Differential complex TX signal (programmable voltage swing)
TXIOUTN RFCONV(5)	UEMK TXIOUTN	Mjoelner TXIN	Input diff. Swing (ref. TxIN)		1.0		Vpp	
TXQOUTP RFCONV(6)	UEMK TXQOUTP	Mjoelner TXQP	DC level	1.0	1.1	1.25	Vdc	
TXQOUTN RFCONV(7)	UEMK TXQOUTN	Mjoelner TXQN	Source impedance			200	Ω	
			Signal frequency		67,7		KHz	
RFAUXCONV(2:0)			RF / BB analogue control signals					
TXC RFAUXCONV(0)	UEMK AUXOUT	Mjoelner TXC	Output voltage	0 - 0.1		2,4 - 2.55	V	Transmitter power control
			Source impedance			200	Ω	
			Resolution		10		Bits	
			Reference		Auxref (VrefRF01 ?)			
			Power coef. Range.	0,05		0,94	Vtxc/ Vtxc_max	
			Recom. Power Coef.1 @ pwr.lvl.5 (0 pcn)	0,7		0,9	Vtxc/ Vtxc_max	
			Recom.Power Coef. @ pwr.lvl.19 (15 pcn)	0,1		0,2	Vtxc/ Vtxc_max	
			Recom.Power Coef @ Base level	0,1		0,2	Vtxc/ Vtxc_max	

Voltage Regulators in BB for RF

Values are referenced to GND unless otherwise specified.

Table 16: Voltage Supplies and References

Signal name	From	To	Parameter	Min	Typ	Max	Unit	Notes
Regulators			RF regulators					
VR1A	UEMK VR1A	Mjoelner VDDCP	UEMK Output Voltage	4.6	4.75	4.9	V	Supply to : Charge pump
			Mjoelner Input Voltage	2.64	2.78	4.9	V	
			UEMK output Load Current	0	(3)	5	mA	
			UEMK Load Capacitance	800	1000	1200	nF	
				20		600	mΩ	ESR
			Settling Time		300+t _{d2}		μs	Sleep to Active
VR2	UEMK VR2	Mjoelner VDDTX VDDDIG	UEMK Output Voltage	2.70	2.78	2.86	V	Supply to TX - chain Modula- tor digital contl logic
			Mjoelner Input Voltage	2.64	2.78	2.86	V	
			Load Current	0.1	(3)	100	mA	
			Load Capacitance	800	1000	1200	nF	
				20		600	mΩ	ESR
			Settling Time	10			μs	Sleep to Active
VR3	UEMK VR3	Mjoelner VDDXO VDDBBB	UEMK Output Voltage	2.70	2.78	2.86	V	Supply to : XO and base- band buffer
			Mjoelner Input Voltage	2.64	2.78	2.86	V	
			Load Current	0.1	(3)	20	mA	
			Load Capacitance	800	1000	1200 (4)	nF	
				20		600	mΩ	ESR
			Settling Time			100	μs	Off to on
				10 ?			μs	Sleep to Active
VR4	UEMK VR4	Mjoelner VDDRxBB	UEMK Output Voltage	2.70	2.78	2.86	V	Supply to : RX baseband section
			Mjoelner Input Voltage	2.64	2.78	2.86	V	
			Load Current	0.1	(3)	50	mA	
VR5	UEMK VR5	Mjoelner VDDPRE VDDL0 VDDPLL	UEMK Output Voltage	2.70	2.78	2.86	V	Supply to : Prescaler, devi- ders, LO buffers, PLL counters
			Mjoelner Input Voltage	2.64	2.78	2.86	V	
			Load Current	0.1	(3)	50	mA	
			Load Capacitance	800	1000	1200 (4)	nF	
				20		600	mΩ	ESR
			Settling Time	10			μs	Sleep to Active
VR6	UEMK VR6	Mjoelner VDDRxF	UEMK Output Voltage	2.70	2.78	2.86	V	Supply to : RX frontend
			Mjoelner Input Voltage	2.64	2.78	2.86	V	
			Load Current	0.1	(3)	50	mA	
			Load Capacitance	800	1000	1200	nF	
				20		600	mΩ	ESR
			Settling Time	10			μs	Sleep to Active

Table 16: Voltage Supplies and References

Signal name	From	To	Parameter	Min	Typ	Max	Unit	Notes
VR7	UEMK	VCO	UEMK Output Voltage	2.70	2.78	2.86	V	Supply to : VCO
			VCO supply voltage range ²	2.55	2.78	2.85	V	
			Load Current	0.1	(3)	45	mA	
			Load Capacitance	800	1000	1200	nF	
				20		600	mΩ	ESR
Settling Time	10			μs	Sleep to Active			
VIO	UEMK VIO	Mjoelner VDDDL	UEMK Output Voltage	1.72	1.88	1.88	V	Supply to: RF-BB inter- face level shifter
			Mjoelner Input Voltage	1.71	1.8	1.88	V	
			Load Current	0.1	(3)	5 ⁽³⁾	mA	
			Load Capacitance					
			Settling Time					
References			RF References					
VREF1	UEMK VREF01	Mjoelner VBEXT	UEMK Output Voltage	1.334	1.35	1.366	V	Used inside MJOELNER as 1.35V refer- ence
			Mjoelner Input Voltage	1.325	1.35	1.375	V	
			Load Current		(3)	100	mA	
			Load Capacitance	800	1000	1200	nF	
				Settling Time				μs

System Connector Interface

System Connector

The system connector in RH-19 (and several other DCT-4 products) is called Pop-Port System Connector (unofficial name: "Tomahawk"). It is a galvanic interface between phone and accessories.

Compared with previous system connector versions, four new functions are introduced with the Pop-port system connector interface:

- Accessory Control Interface (ACI)
- Power Out
- Stereo audio output
- Universal Serial Bus (USB).

USB functionality and stereo audio output of the Pop-port are not supported in RH-19.

Note: MBUS function, (included in previous accessory interfaces, e.g. DCT-3) is no more supported by Pop-port interfaces.

Pop-port system connector is **mechanically and electrically not backward compatible** with any earlier Nokia accessory interfaces, except the charger connector.

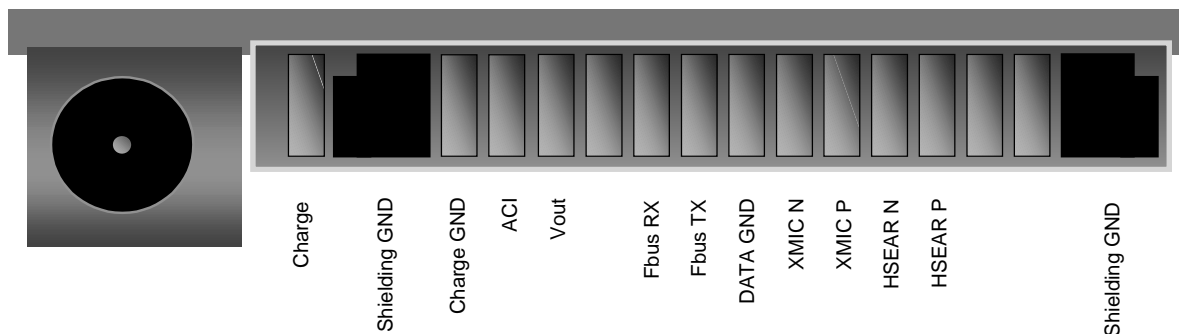

Figure 15: Pop Port System Connector

Table 17: System connector interface description

Pin #	Signal	Notes
1	VCHAR	
2	GND	Charge ground
3	ACI	Insertion & removal detection / Serial data bi-directional 1 kbit/s
4	Vout	
5		Not used in RH-19
6	FBUS_RX	Serial data from accessory to phone / 115 kbit/s
7	FBUS_TX	Serial data from phone to accessory / 115 kbit/s
8	GND	Data ground
9	XMIC N	Negative audio in signal
10	XMIC P	Positive audio in signal
11	HSEAR N	Negative audio out signal. Max bandwidth from the phone
12	HSEAR P	Positive audio out signal. Max bandwidth from the phone
13		Not used in RH-19
14		Not used in RH-19

Accessory Control Interface (ACI)

ACI is a point-to-point, master-slave, and bi-directional serial bus. It has three features:

- The insertion and removal detection of an accessory device
- Acting as a data bus, intended mainly for control purposes
- The identification and authentication of accessory type which is connected

The accessories are detected by the HeadInt signal when the plug is inserted.

Normally when no plug is present, the pull-up resistor 100k pulls up the HeadInt signal to VFLASH1. If the accessory is inserted, the external "insertion & removal" resistor works as voltage divider and decrease the voltage level below the threshold Vhead.

Thereby the comparator output will be changed to high state causing an interrupt.

If the plug is removed, the voltage level of HeadInt increases again to VFLASH1. This voltage level is higher than the threshold of the comparator and thereby its output will be changed to low. These changes lead to an interrupt.

These HeadInt interrupts are initiated the accessory detection or removal sequence.

If no accessory inserted / connected the only active part on the Pop-port interface is the ACI line.

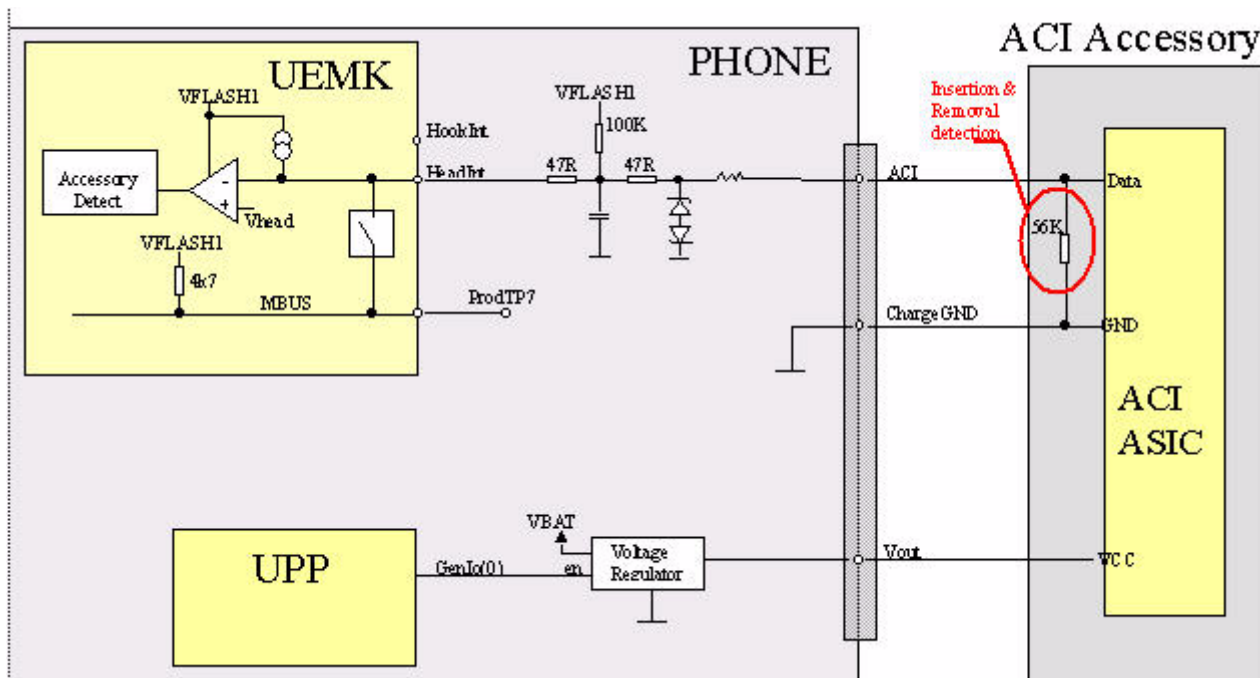

Figure 16: Principle schematics of ACI Accessory and engine

Signal flow on ACI line - ACI-ASIC accessory inserted

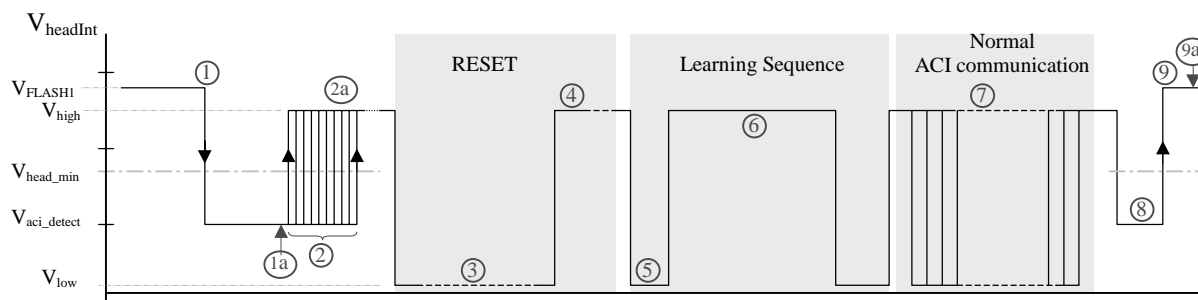

Figure 17: ACI communication

1. Accessory is connected (insertion & removal resistor connect to ACI line)
- 1a) phone gets HeadInt interrupt after 20ms check that ACI line is still low (<Vhead_min)
2. Connect MBUS with HeadInt line (MBUS switch)
- 2a) If the phone detect a HeadInt interrupt from low to high transition in 20ms time-frame, then an advanced accessory is connected

3. ACI chip reset (3000- 4000us)
4. Power up delay (50-400us)
5. Start bit (50us)
6. Learning sequence (567-1700us)
7. ACI communication
8. MBUS is disconnected from HeadInt line (MBUS switch). After every communication.
9. Accessory is removed (no insertion & removal resistor on ACI line) --> phone gets HeadInt interrupt from ACI line low to high transition.
- 9a) If no HeadInt interrupt comes in the next 100ms the accessory is really removed and the phone goes in the state "no accessory".

Table 18: Voltage Levels

Signal	Min	Typ	Max	Unit	Note
V_{FLASH1}	2.7	2.78	2.86	V	
V_{head}	1.75	1.9	2.05	V	
Specified values for levels	Min	Typ	Max	Unit	Note
V_{ACI_detect}	0.83		1.13	V	Voltage level if MBUS not connected to HeadInt (MBUS switch open), but ACI accessory is inserted.
V_{high}	2.45		2.71	V	Voltage level after MBUS connected to HeadInt.
V_{low}		$<0.22*VDD$		V	

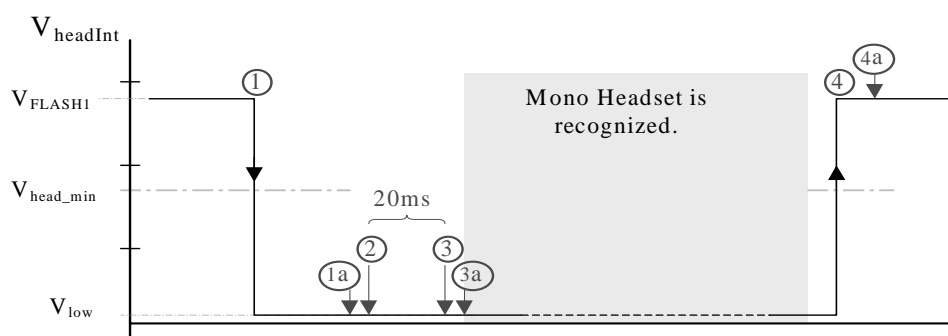
Signal flow on ACI line - Non ACI-ASIC accessory inserted**Figure 18: Signal flow on ACI Line**

1. Accessory is connected (insertion & removal resistor connect to ACI line)
- 1a) phone gets HeadInt interrupt after 20ms check that ACI line is still low ($<V_{head_min}$)
2. Connect MBUS with HeadInt line (MBUS switch)
3. The 20 ms timer elapsed and no transition has been on HeadInt line
- 3a) Disconnect MBUS from HeadInt line
4. Accessory is removed. Phone gets HeadInt interrupt from ACI line low to high transition.

4a) If no HeadInt interrupt comes in the next 100ms the accessory is really removed.

FBUS

FBUS is an asynchronous data bus with separate TX and RX signals. Default bit rate of the bus is 115.2 Kbit/s.

FBUS is used as additional communication channel from phone to accessory and vice versa. There is two types of accessories which it uses:

1. Nokia Serial Bus Accessory, AT mode
2. Fbus Phonet mode accessory

From HW-point of view, this does not make any difference.

Table 19: FBUS interface

Signal	Parameter	Min	Typ	Max	Unit
FBUS_RX	V _{IH}	1.95	2.78	3.0	Volt
	V _{IL}	0	0.2	0.83	
FBUS_TX	V _{OH}	1.95	2.78	2.83	
	V _{OL}	0	0.2	0.83	

VOUT (Accessory Voltage Regulator)

DCT4 chip set does not provide and power supply for accessories. To enable this an external LDO regulator is needed. This regulator is called "Accessory Regulator".

The regulator input is connected directly to battery voltage VBAT and the output to VOUT pin at system connector. The regulator is controlled by the GENIO(0) line of UPP. With this signal the regulator can be switched on and off.

The regulator can be supply up to150 mA. (Note: this exceeds the Pop-port minimum requirement)

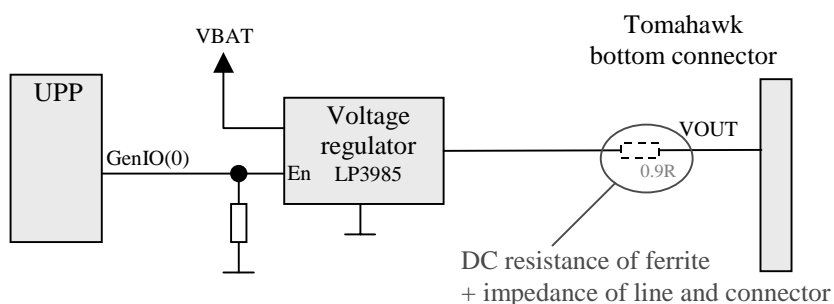

Figure 19: Accessory Power Supply Diagram

Table 20: Accessories Power Supply

Signal	Min	Nom	Max	Unit	Note
Vout	2.63 2,56	2.80	2.88	V	I = 70mA I _{max} = 150mA
GenIO(0)	1.4	1.88 0.6	0.6	V	High (ON) Low (OFF)

The pull-down resistor on the enable input of the regulator is needed because in the switch-off mode of the phone, the output level of the Genio(0) is not defined. Without this resistor's the output of the regulator can be floating.

RH-19 supports fully differential external audio signals. A headset can be connected to the Pop-port system connector. However, only Mono audio is supplied to accessories.

HookInt

This signal is used to detect whether a button in accessory is pressed or not. The hook signal is generated by creating a short circuit (20 ohm) between the headset microphone signals (XMICP and XMICN). In this case, an LP-filter is needed on the HookInt input to filter the audio signal.

If no accessory is present, the HookInt signal is pulled up by the UEMK resistor.

If an accessory inserted and the microphone path is biased the HookInt signal decreases to 1.9V due to the microphone bias current flowing through the resistor. When the button is pressed the microphone signals are connected together, and the HookInt input will get half of micbias dc value 1.1V. This change in DC level will cause the HookInt comparator output to change state, in this case from 0 to 1.

HookInt comparator reference is selected level is 1.35 V.

Normally micbias and hookint are enabled only when audios are routed to headset.

In order to recognize the Hook signal (button in headset or SyncButton in deskstand), during the phone is in the sleep mode, it must be done by polling. That means the micbias and the hookInt signal must be enabled in regular time intervals.

Table 21: Voltage Levels Hook Int

Signal	Min	Nom	Max	Unit	Note
VFLASH1	2.7	2.78	2.86	V	
MICB2	2.0	2.1	2.25 600	V uA	
Vhook1	1.25	1.35	1.45	V	

Charging

RH-19 can be charged via a DC-plug or charging pins on the system connector. Furthermore, it supports only 2-wire charging.

DC-Plug

Like most Nokia phones, RH-19 uses a 3.5mm DC-plug. Nevertheless, it is possible to use a 3-wire charger, but the PWM inside these chargers is not supported.

VCHAR Pins of System Connector

The VCHAR and ChargeGND pin are directly connected to the normal charger lines of the DC-plug.

Table 22: Charger Input Voltage Levels

Signal	Min	Nom	Max	Unit	Note
Input voltage range (fast charger)	5.5	8.4	9.3	VRMS	I= 850mA
Input voltage range (standard charger)		11.1 7.9	16	Vpeak VRMS	
	-0.3		20	V	Absolute maximum VHAR voltage

Voltages and Currents

Table 23: System connector interface signals

Pin #	Signal	Parameter	Min	Typ	Max	Unit	Notes
1	VCHAR		0		9 0.85	VDC ADC	
2	GND						Charge ground
3	ACI	Logic "0"	0	0.2	0.7	V	Insertion & removal detection / Serial data bi-directional 1 kbit/s
		Logic "1"	1.7	2.78	2.86		
4	Vout	Output voltage	2.56	2.8	2.88	VDC	70mA is specified as the max. current in the Pop-port specification
		Current		70	150	mA	
5							Not used in RH-19
6	FBUS_RX	Logic "0"	0	0.2	0.86	V	Serial data from accessory to phone / 115 kbit/s
		Logic "1"	2.0	2.78	3.0		
7	FBUS_TX	Logic "0"	0	0.2	0.81	V	Serial data from phone to accessory / 115 kbit/s
		Logic "1"	1.89	2.78	2.83		
8	GND						Data ground
9	XMIC N	Differential voltage swing		1		Vpp	Negative audio in signal
		DC level	?	?	?	VDC	
10	XMIC P	Differential voltage swing		1		Vpp	Positive audio in signal
		DC level	2.05	2.1	2.25 400	VDC uA	
11	XEAR N	Differential voltage swing	1			Vpp	Negative audio out signal. Max bandwidth from the phone
12	XEAR P	Differential voltage swing	1			Vpp	Positive audio out signal. Max bandwidth from the phone
13							Not used in RH-19 (grounded)
14							Not used in RH-19 (grounded)

Baseband Calibration

Energy Management Calibration

Dispersion in UEM AD-converters and external components must be compensated.

EM Calibration is used for calibrating Battery and Charger settings of the phone.

Table 24: BB Calibration limits

AD channel	Min	Max
ADC OFFSET	-100	100
ADC GAIN	25400	29000
BSI GAIN	860	1180
BTEM GAIN	1980	2280
VBAT SCAL OFFSET	2300	2900
VBAT SCAL	10000	11000
VCHAR	58000	62000
ICHAR GAIN	3850	4950

Calibration method with JBV-1

Calibration is easiest done by using JBV-1 box in conjunction with Phoenix Service SW

Preparation for EM Calibration:

- Connect DC Cable SCB-3 between JBV-1 and Vin of Phone for Charger calibration.
- Connect 12...15 V from Power Supply to JBV-1.
- NOTE! Check that connection is F-BUS (does not work with M-BUS!).

Select Maintenance => Tuning => Energy Management Calibration.

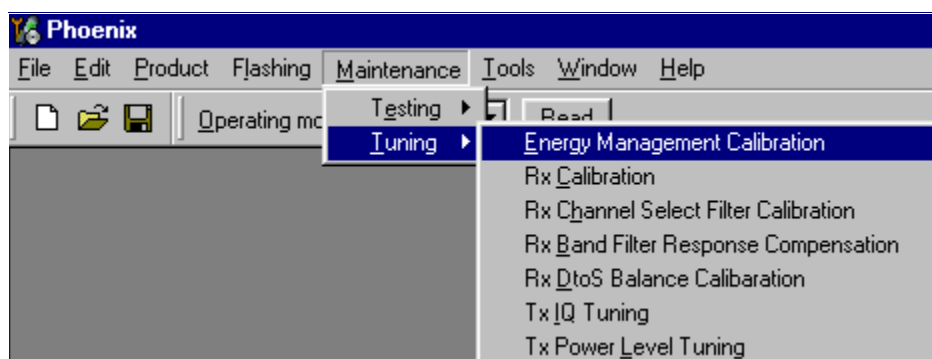

Energy Management values to be calibrated are checked.

Select "Read from Phone" to show the current values in the phone memory and to check that the communication with the phone works.

Select "Calibrate" to run the selected calibrations.

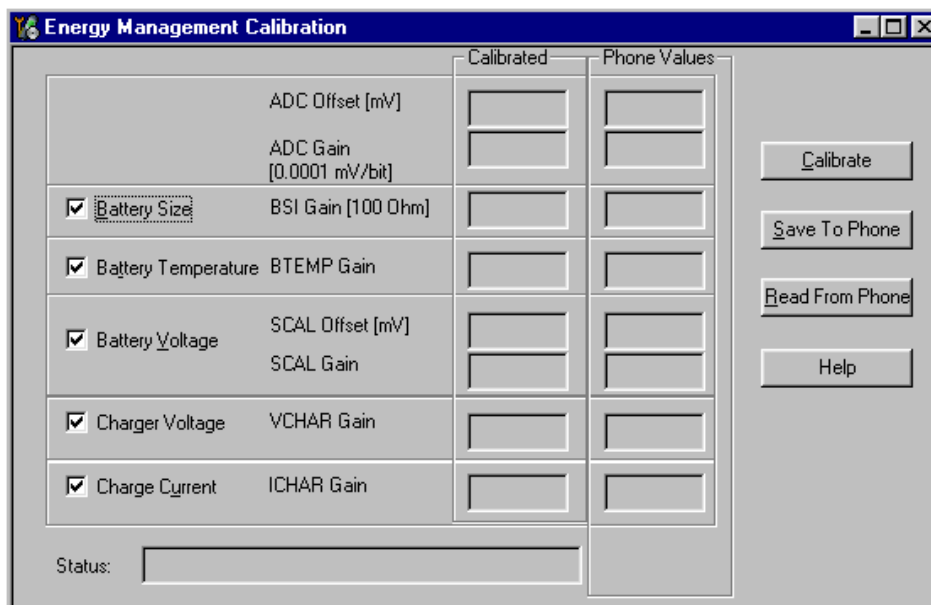

Calibration method without JBV-1

Calibration for RH19 must be done in LOCAL-mode.

ADC-converter calibration is made with two different calibration points.

- Connected 0.7V to BSI line -> read AD-converter value.
- Connected 2.1V to BSI line -> read AD-converter value.
- SAVE VALUE to PMM (Permanent Memory) area.

BSI calibration is made in order to get correct battery information.

- Set to BSI line 1% 68kohm resistor -> read AD-converter value.
- SAVE VALUE to PMM (Permanent Memory) area.

VBATT calibration is made in order to get correct battery voltage.

- Set to VBATT line 3.1V and 4.2V -> read AD-converter value.
- SAVE VALUE to PMM (Permanent Memory) area.

VCHARGE calibration is made in order to get charger types and charger voltages correct.

- Connect 8.4V to charger line -> read AD-converter value.
- SAVE VALUE to PMM (Permanent Memory) area.

Charge current calibration is made order to get correct charge current.

- Connect 500mA to charger line -> read AD-converter value.

If values shown are within limits select "Save To Phone" to save the values in the phone.

NOTE! Only the values of the checked tunings (Battery size, Battery Temperature etc...) are saved.

Close the "Energy Management Calibration" – dialog to end tuning.

You must manually switch the phone on after exiting "Energy Management Calibration" – dialog.

LCD Contrast Tuning

Extra equipment not needed

This function is used to calibrate the LCD Contrast

Must be done when LCD module is replaced and there is a considerable difference in the contrast!

Select TEST mode if not already selected.

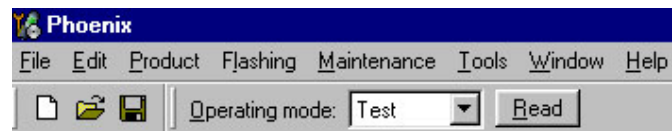

Select Maintenance => Testing => Display Test

Select Test =>Pattern test

Select Test Pattern => Chess pattern

Select Lights => Display

Select => Send To Phone.

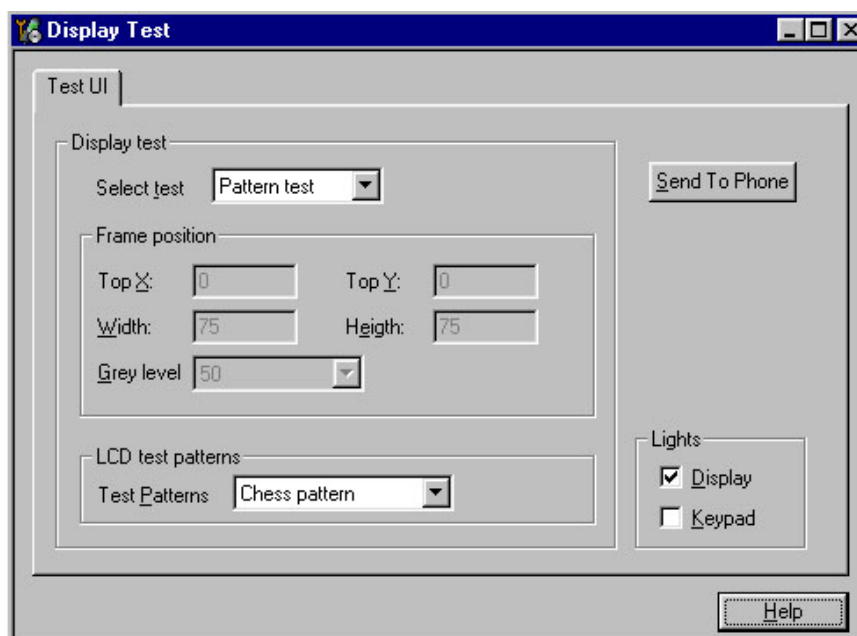

Select Maintenance => Testing => Display Tune

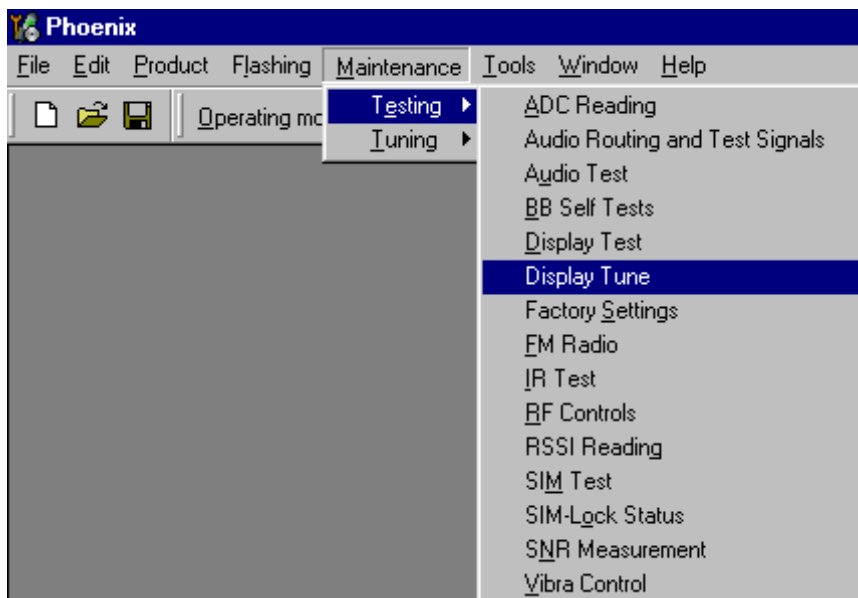

Press "Default" button and following default values will be set;

"Contrast offset slider" is set to 0% (See picture below)

"Contrast Factory offset" slider is set 41

Tune the Contrast by using "Contrast Factory offset" slider.

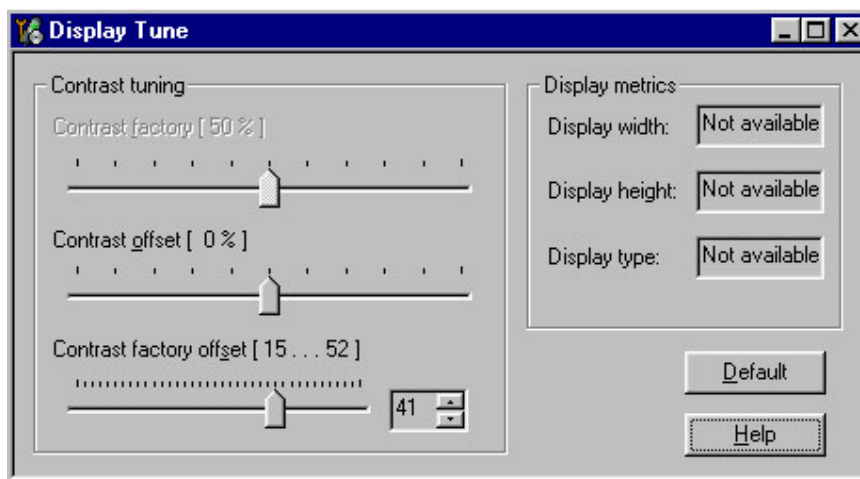

Close the "Display Tune" – dialog to end tuning.

Check the contrast from the Phone UI.

Check that the brightness has been set to default from Phone's menu 4-4-5

Baseband Testpoints

List and Description

Table 25: RH-19 test points

Signal	Test point	Function	Characteristics	Note
FBUSTX	J411	Flash programming data and phone control	1.8V during read phone information 1.8V digital signal	From phone to FPS-8/PC
FBUSRX	J412	Flash programming data and phone control	1.8V during read phone information 1.8V digital signal	From FPS-8/PC to phone
BSI	X103	Battery size indicator Local mode indicator	1V in normal mode 0V in local mode	To UEM A/D converter
BTEMP	J102	Battery temp. indicator	About 0.8V at 25°C	
VSIM	X387, pin 3	Power supply for SIM card	1.8V or 3V	Depends on the SIM card
PURX	J402	Power up reset	1.8V digital signal	From UEM to UPP
SLEEPX	J403	Sleep mode control signal	1.8V when key is pressed	
SLEEPCLK	J404	Sleep mode timing clock	32.768kHz digital clock 1.8V	
CBUSDA	J407	Serial control bus data input/output	1.8V digital signal	Between UPP (MCU) and UEM Controlled by MCU
CBUSENX	J408	CBUS enable signal	1.8V digital signal	From UPP (MCU) and UEM Controlled by MCU
RFCLK	R420	System clock for Baseband	26 MHz analog clock signal >300 mVpp	
RESX	J308/V301	LCD reset	1.8V digital signal	From UPP to LCD driver
CSX	J311/R310	LCD chip select	1.8V digital signal	From UPP to LCD driver
DBUSCLK	J413	DBUS clock	13 MHz digital clock signal 1.8V	From UPP (DSP) to UEM Generated by UPP
VBATT	X103		3.7V	
VIO	C207		1.8V	
VCORE	C208		1.5V	
VANA	C206		2.8V	
VR3	C227		2.8V in local mode 2.8V pulse in normal mode	
VFLASH1	C205		2.8V	
VDD	J314/C300		2.8V	Measurement not possible in AMS-Jig
VDDI	J315/C301		1.8v	Measurement not possible in AMS-Jig
ROW0	J320		1.8V	From Z300 to Vol.-key
ROW1	J321		1.8V	From Z300 to Vol.-key
COLO	J325		1.8V pulse	From Z300 to Vol.-key
EMU1	J488	Emulator 1	Digital signal	

Table 25: RH-19 test points

Signal	Test point	Function	Characteristics	Note
JTRst	J481	JTAG Reset	Digital signal	
STIClk	J472	STI Clk	Digital signal	
STIRxD	J473	STI Receive	Digital signal	
JTDI	J482	JTAG TDI	Digital signal	
JTDO	J484	JTAG TDO	Digital signal	
UEMINT	J405	UEM Interrupt	Digital signal	
DBUSEN1x	J415	DBUS Enable	Digital signal	
EMU0	J487	Emulator 0	Digital signal	
JTCIk	J486	JTAG Clk	Digital signal	
JTMS	J480	JTAG TMS	Digital signal	
FLS2CSX	J418	Flash 2 Chip Select	Digital signal	
DBUSDA	J414	DBUS Data	Digital signal	

Testpoints on Bottom-Side

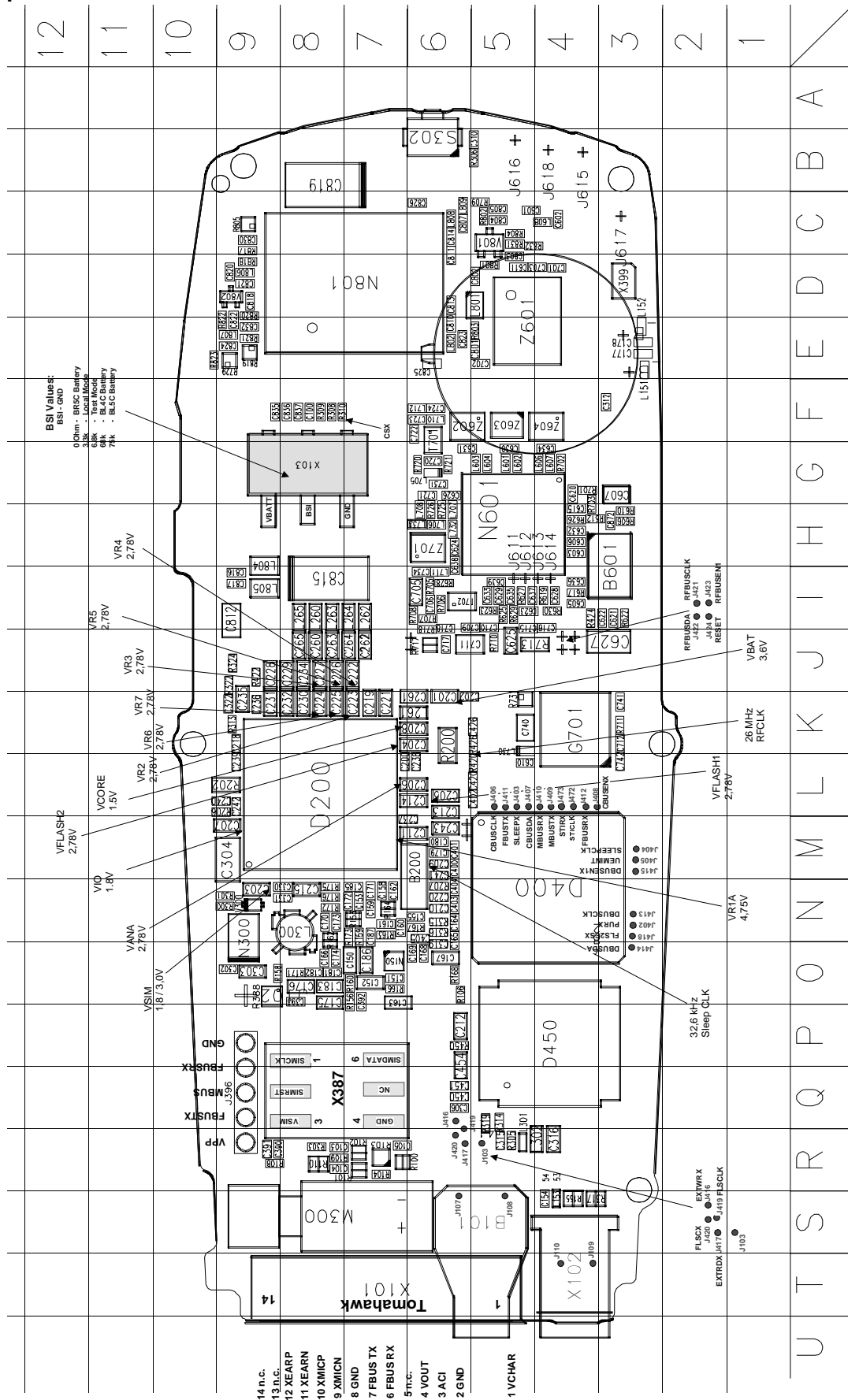

Testpoints on Top-Side

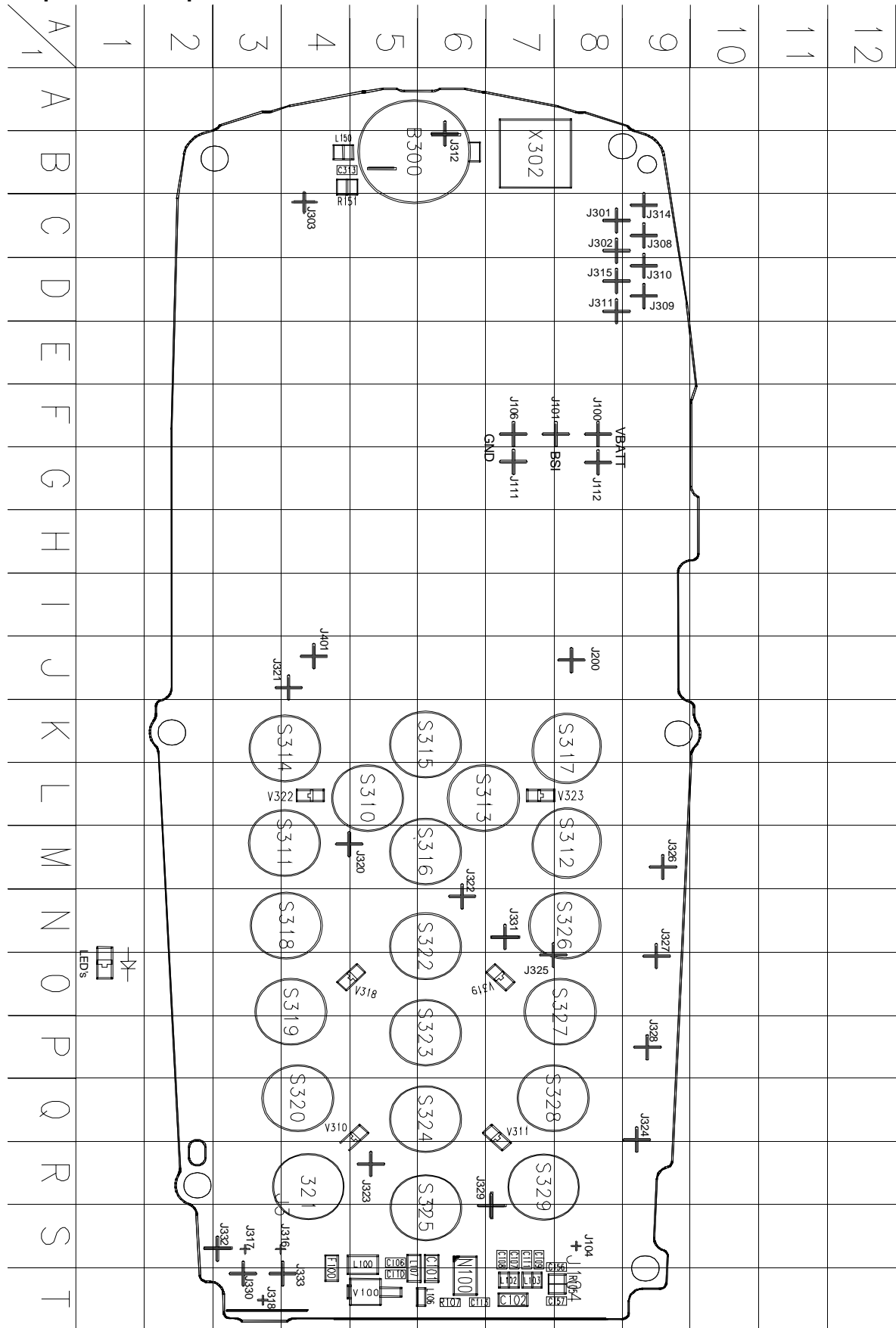

Baseband Trouble Shooting

This document outlines the various possibilities that may be encountered with respect to the repair of the RH19 product (3100). It covers only the baseband parts of the product, for problems within the RF parts, please refer to the RF trouble-shooting guide. The document describes the necessary test equipment required to debug problems and also advises on possible routes that can be taken to solve the problem under investigation.

It is assumed that when using the flow diagrams in this document, it is in conjunction with the layout sheets, thus grid locations to the left of the flow diagrams reference these sheets.

In addition, grid references are labeled normally if they are on the bottom-side of the layout and marked with '#' in case they are on the topside of the layout. (Topside is the side with keypad and display connector)

Note: Values listed are specified values. These values have tolerances that should be taken into consideration when making measurements.

Top Level Flowchart

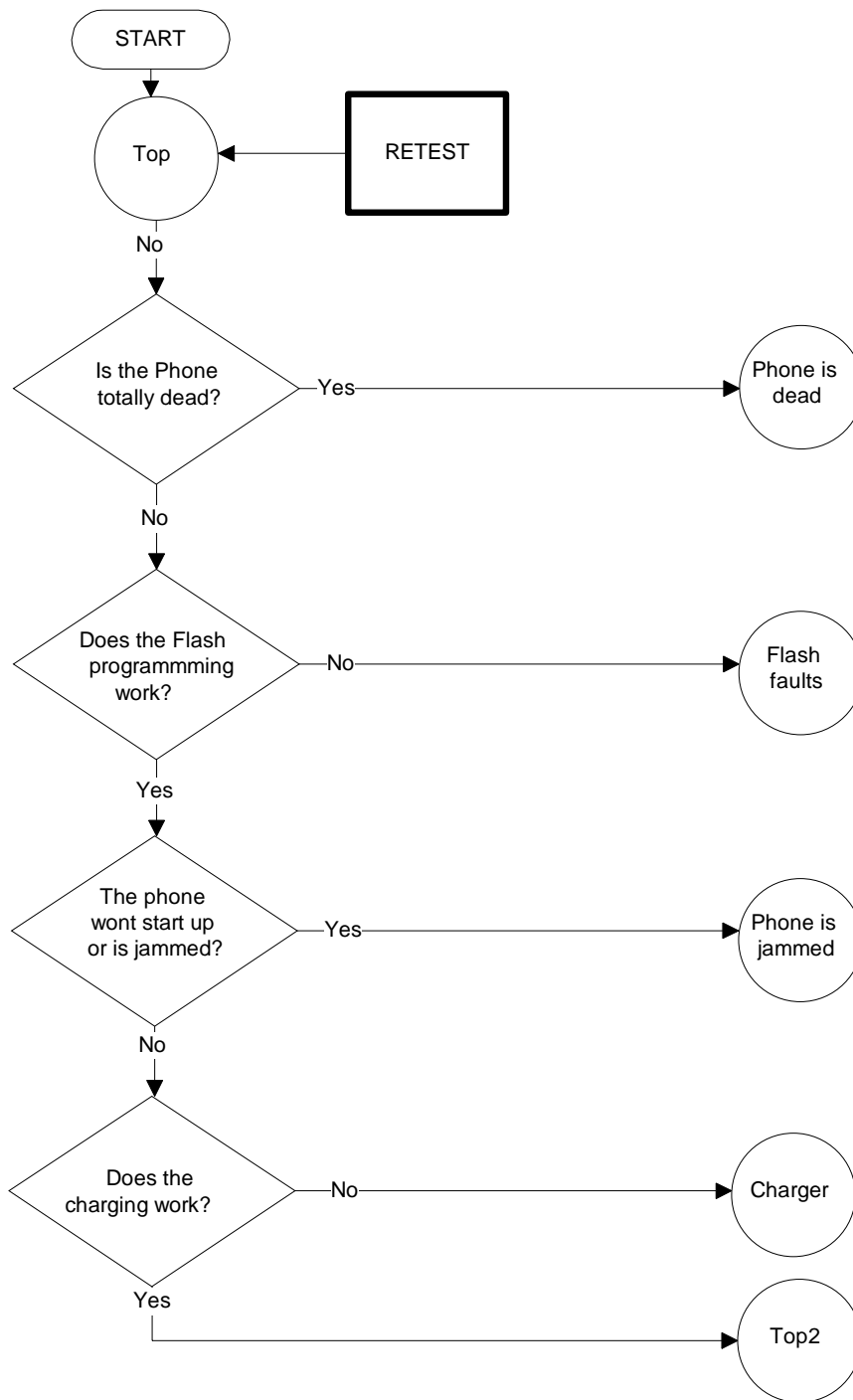

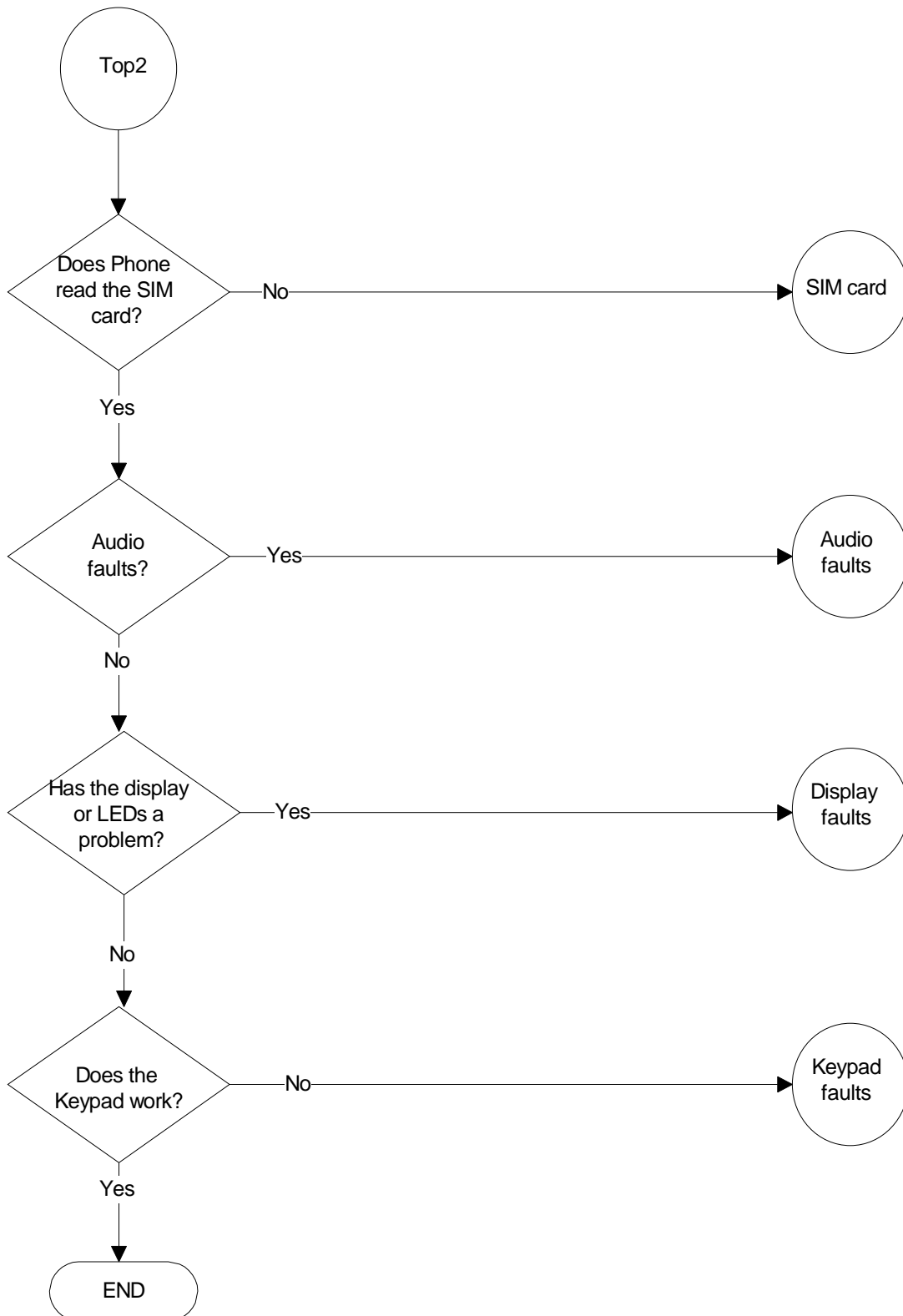

Phone is Dead

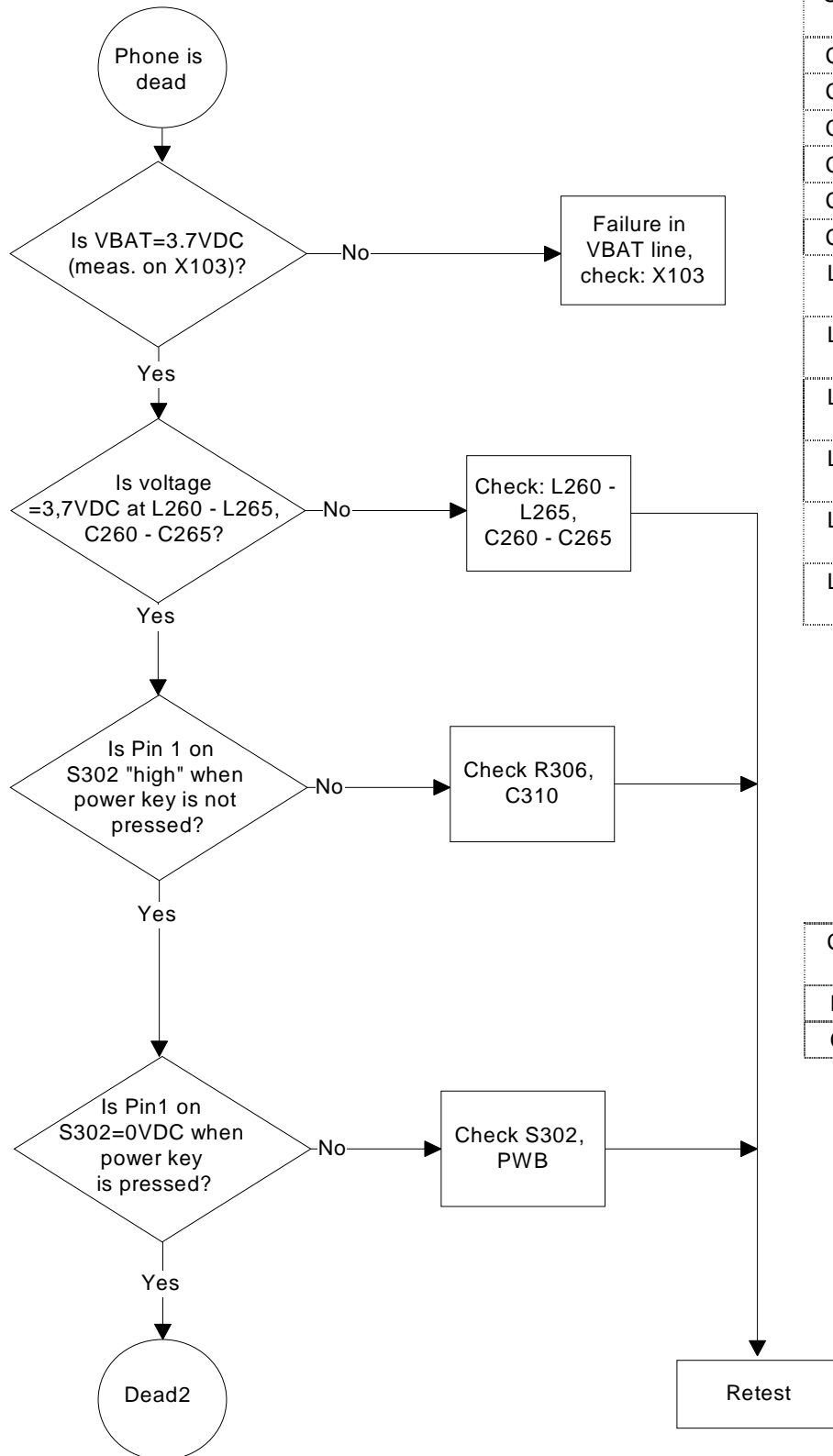

Comp	Value	Grid Loc.
C260	1u0	J 7
C261	1u0	K 6
C262	1u0	J 7
C263	1u0	J 7
C264	1u0	J 7
C265	1u0	J 8
L260	600R/100 MHz	I 7
L261	600R/100 MHz	K 6
L262	600R/100 MHz	I 7
L263	600R/100 MHz	I 7
L264	600R/100 MHz	I 7
L265	600R/100 MHz	I 8

Comp	Value	Grid Loc.
R306	27k	B 5
C310	22p	B 5

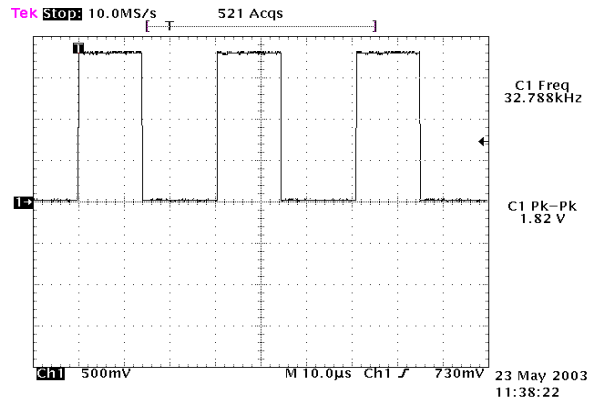
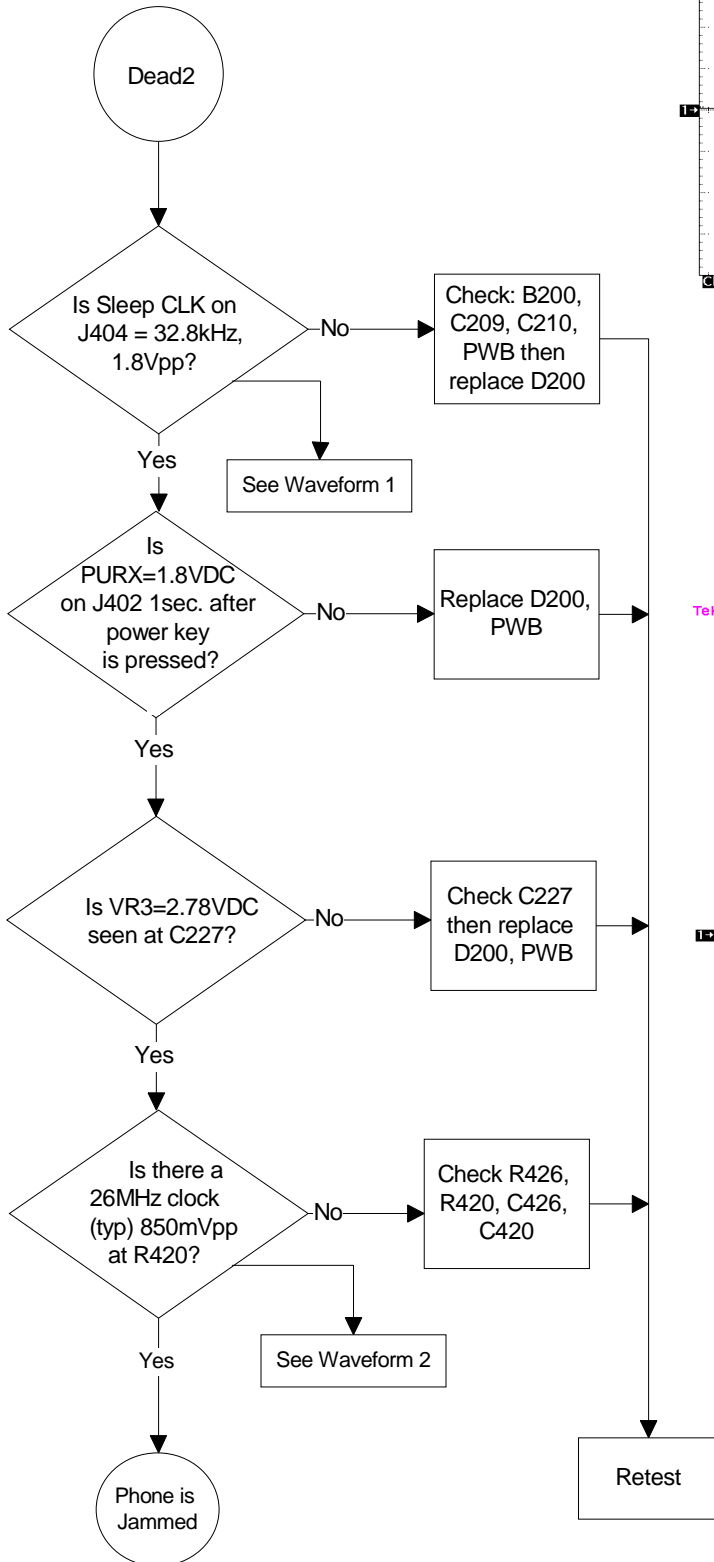

Comp	Value	Grid Loc.
B200	32.768 kHz	M 6
C209	10p	M 6
C210	10p	N 6

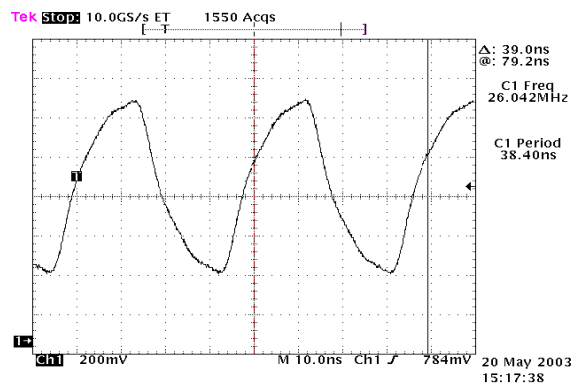

Comp	Value	Grid Loc.
R420	1k0	L 5
R426	1k0	K 5
C420	47p	L 5
C426	1n0	K 5

Comp	Value	Grid Loc.
C227	1u0	J 7

Flash Faults

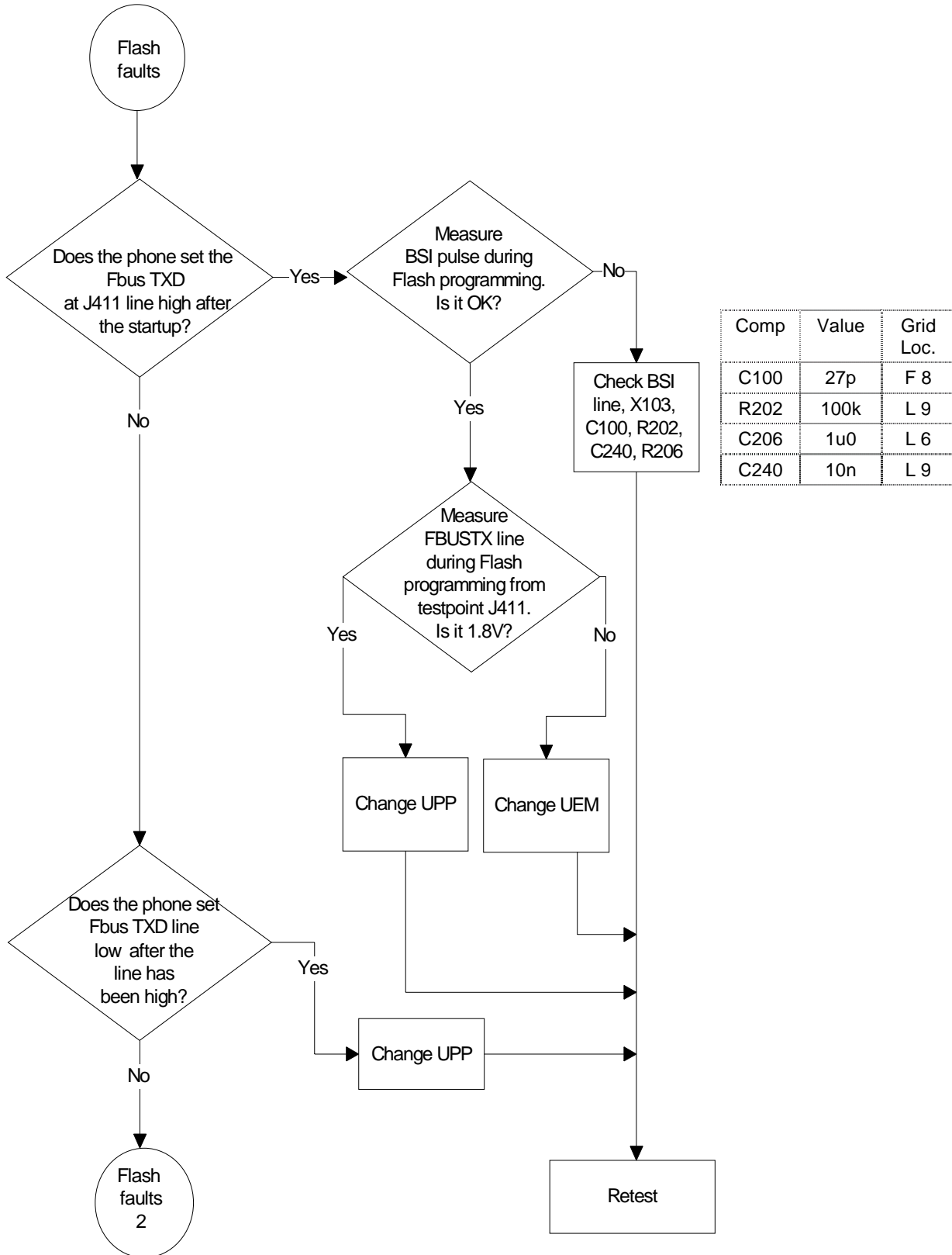

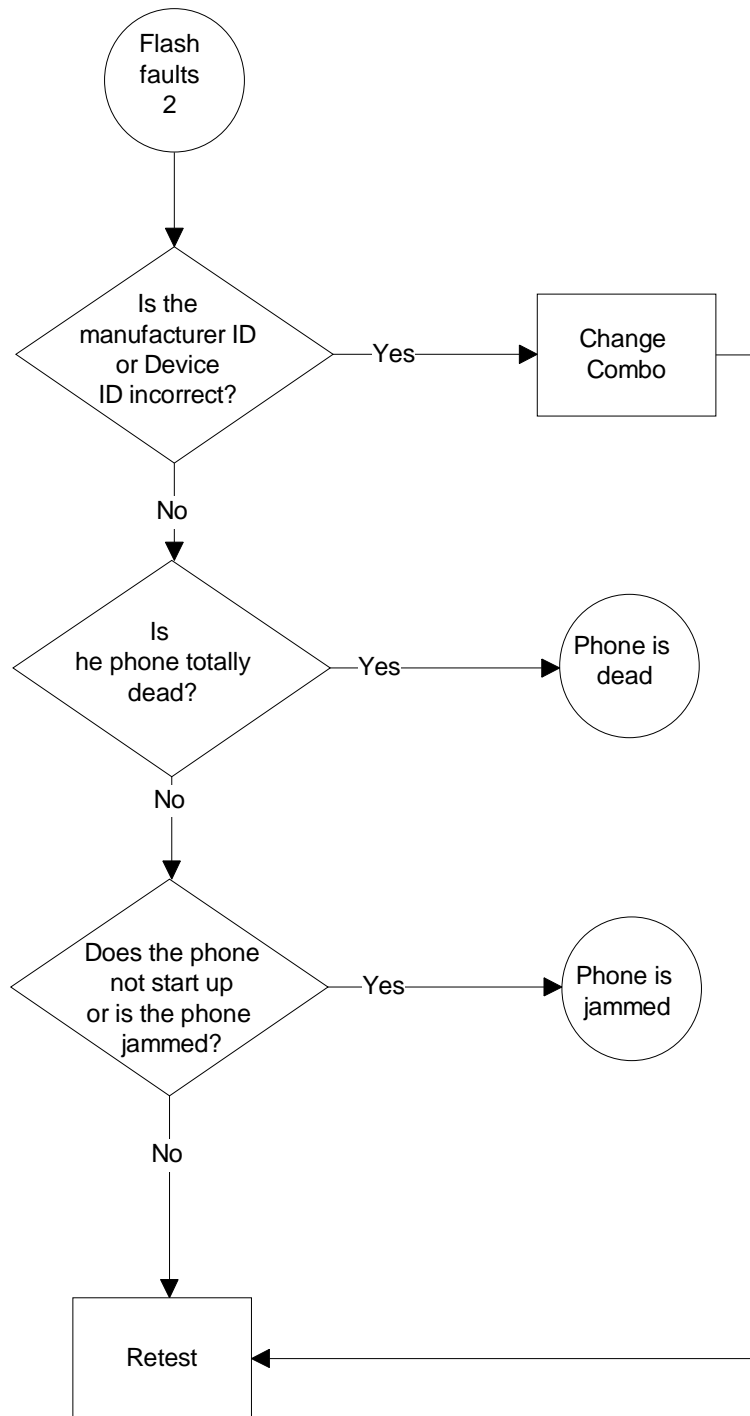

Phone is Jammed

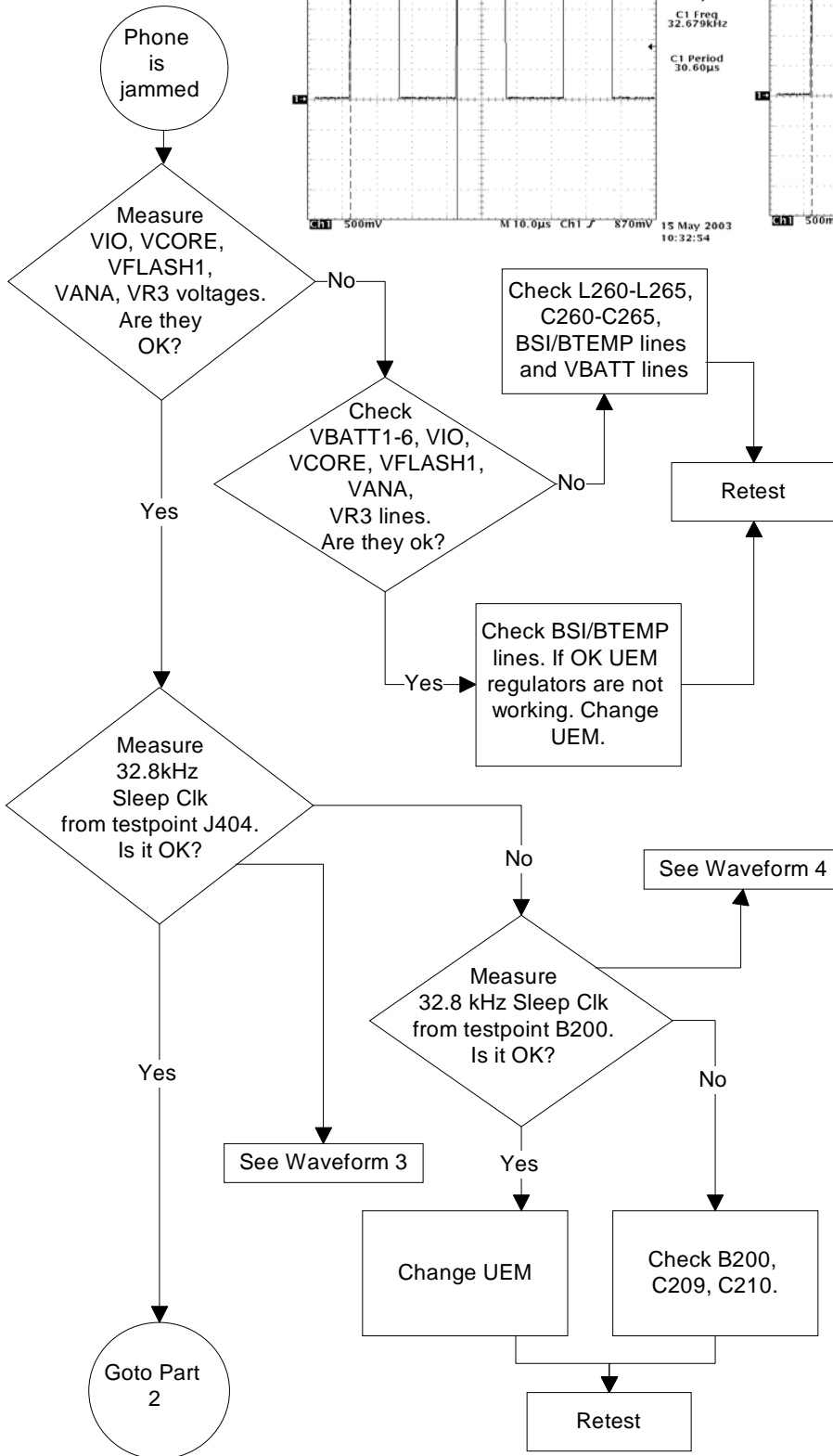
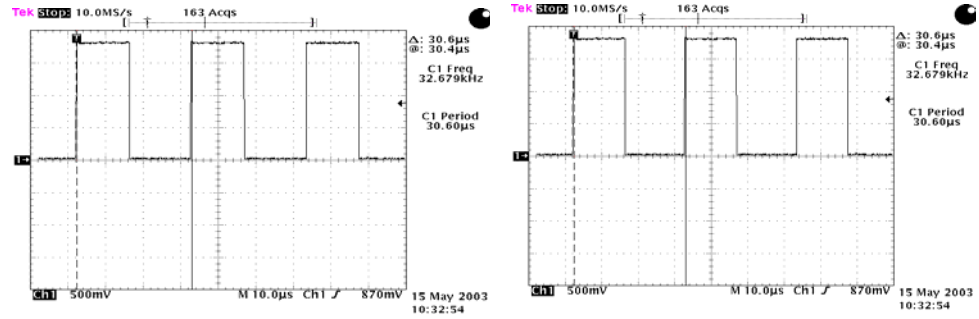

Comp	Value	Grid Loc.
L260	600R/100 MHz	I 7
L261	600R/100 MHz	K 6
L262	600R/100 MHz	I 7
L263	600R/100 MHz	I 7
L264	600R/100 MHz	I 7
L265	600R/100 MHz	I 8
C260	1u0	I 7
C261	1u0	K 6
C262	1u0	I 7
C263	1u0	I 7
C264	1u0	I 7
C265	1u0	I 8

Comp	Value	Grid Loc.
R420	1k0	L 5
R426	1k0	K 5
C420	47p	L 5
C426	1n0	K 5
N601	ASIC	H 4
B200	32.768 kHz	M 6
C209	10p	M 6
C210	10p	N 6

Comp	Value	Grid Loc.
R420	1k0	L 5
R426	1k0	K 5
C426	1n0	K 5
C420	47p	L 5
N601	ASIC	H 4
J402	TP	N 3

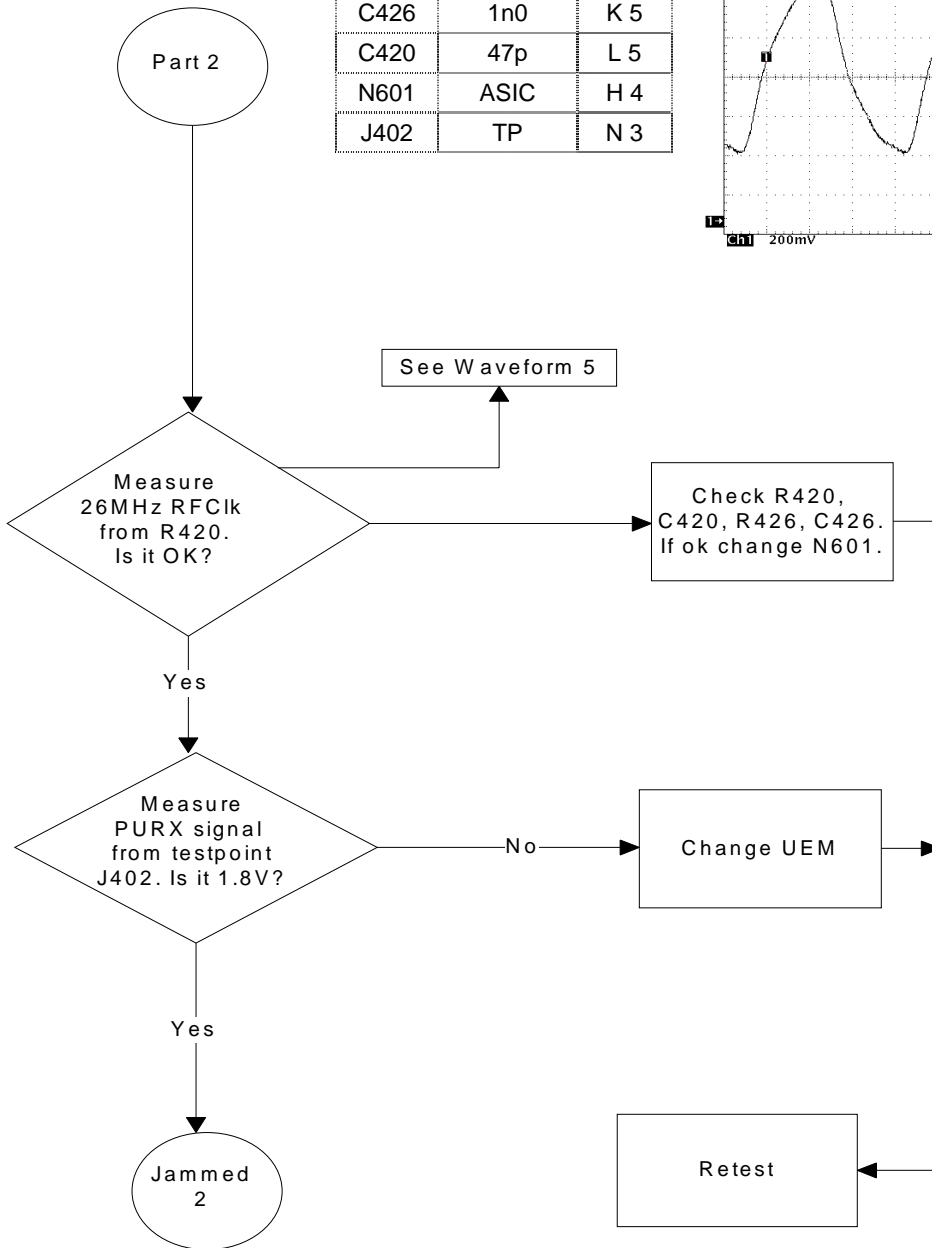
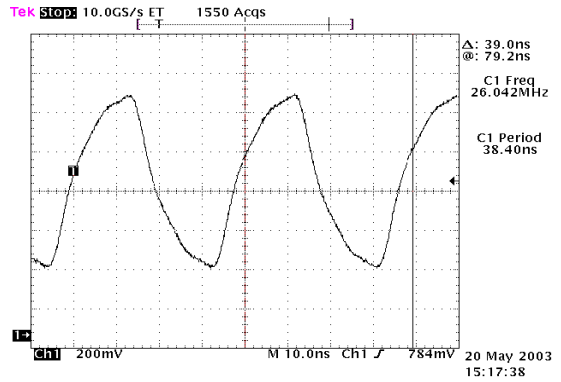

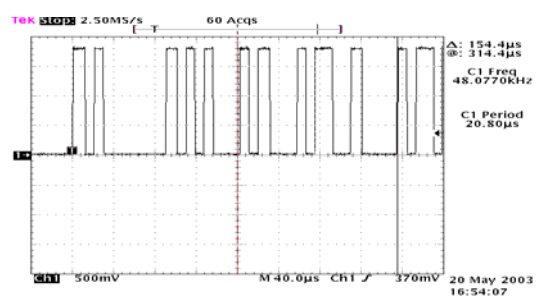
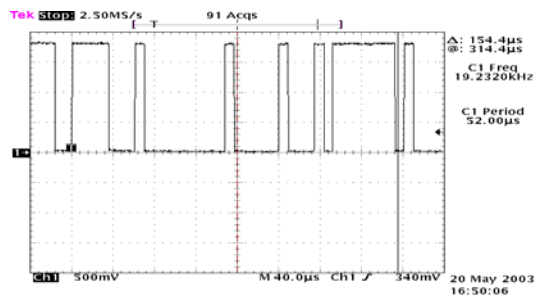
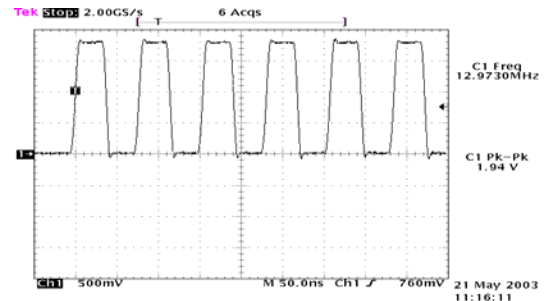
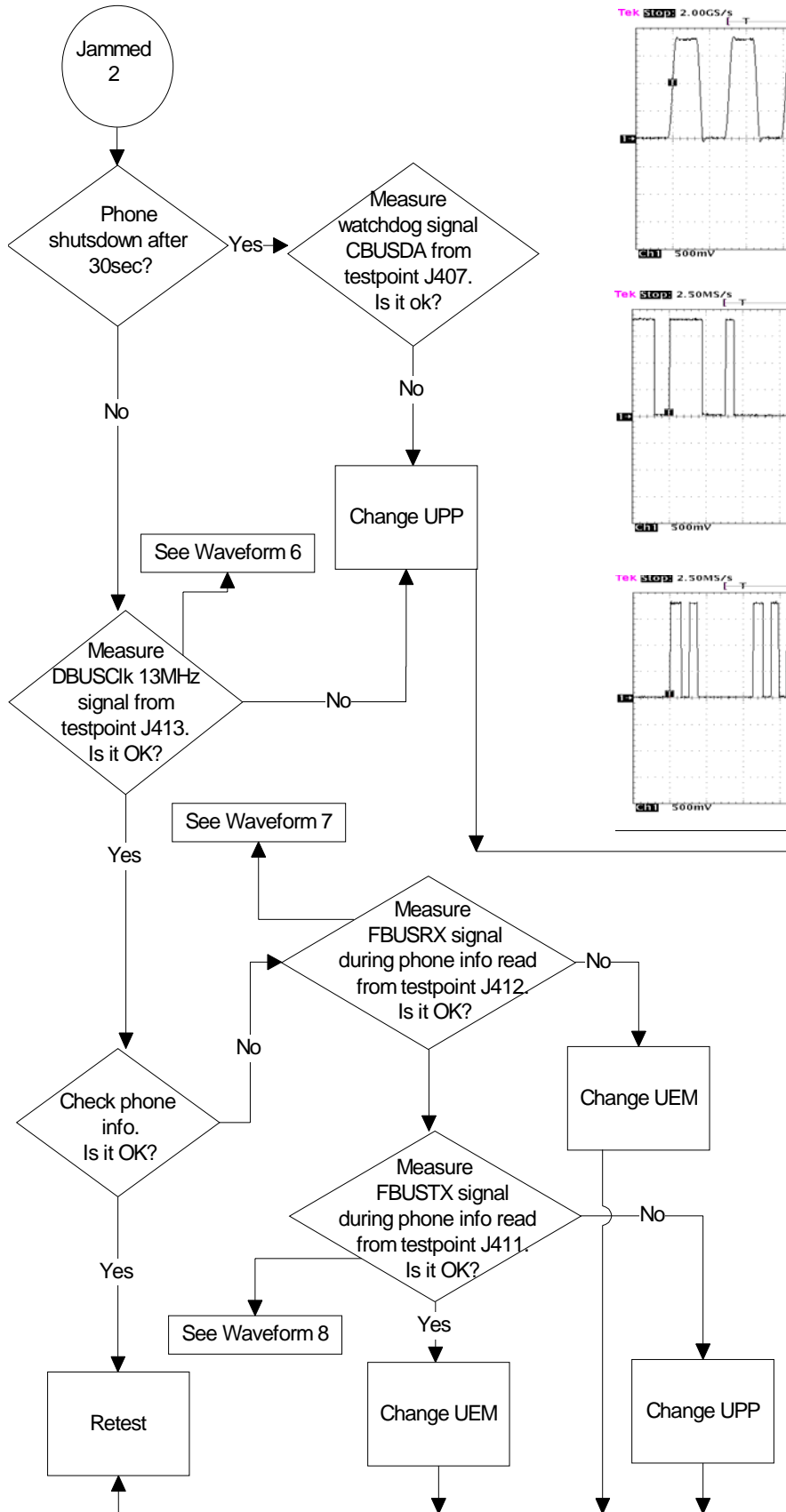

Charger

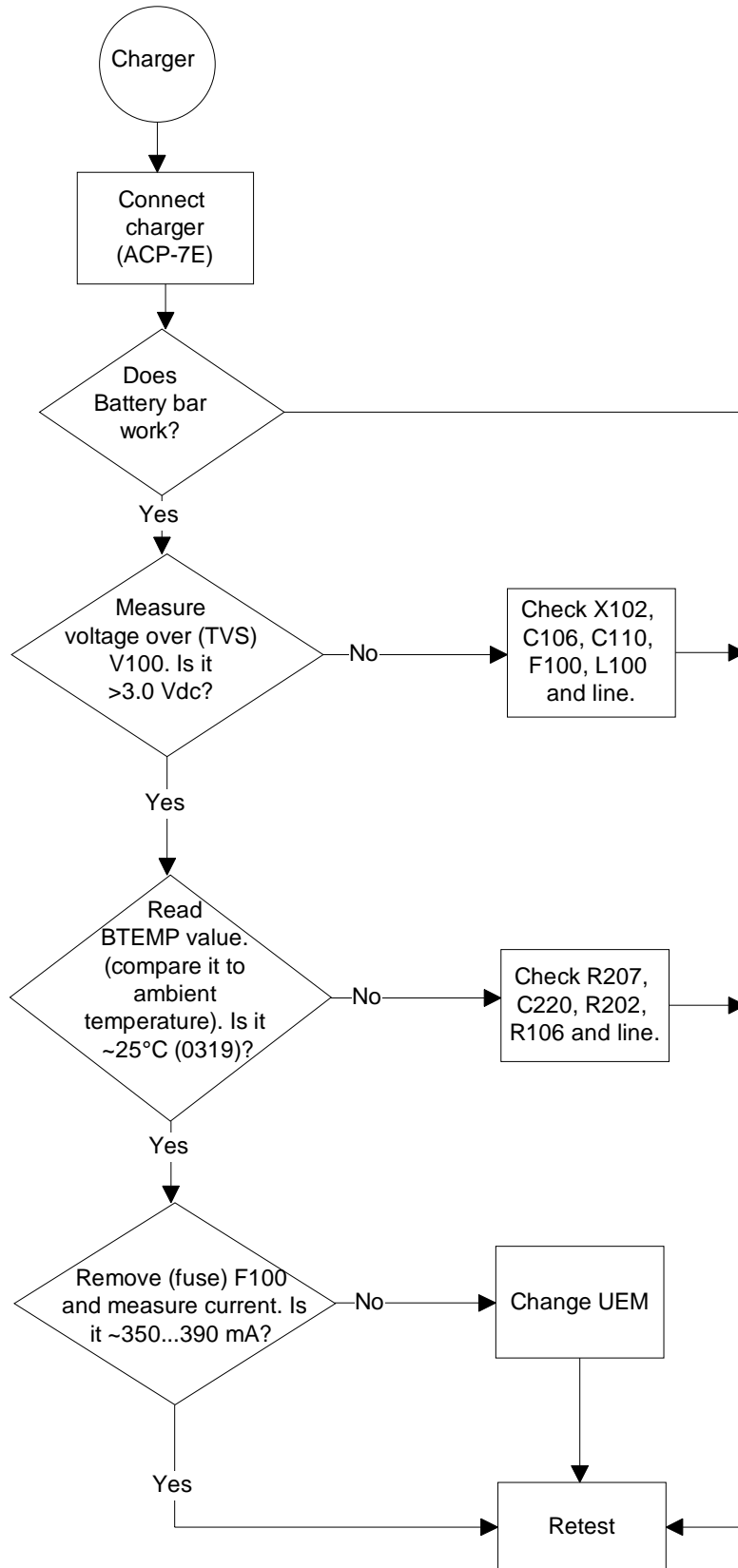

Comp	Value	Grid Loc.
V100 #	-	T 5
C106 #	1n0	S 5
C110 #	22p	T 5
F100 #	1.5A	S 4
L100 #	42R/100MHz	S 5
R207	4k7	N 6
C220	10n	N 6
R202	100k	L 9
R106	47k	O 5
# Topside components		

SIM Card Error

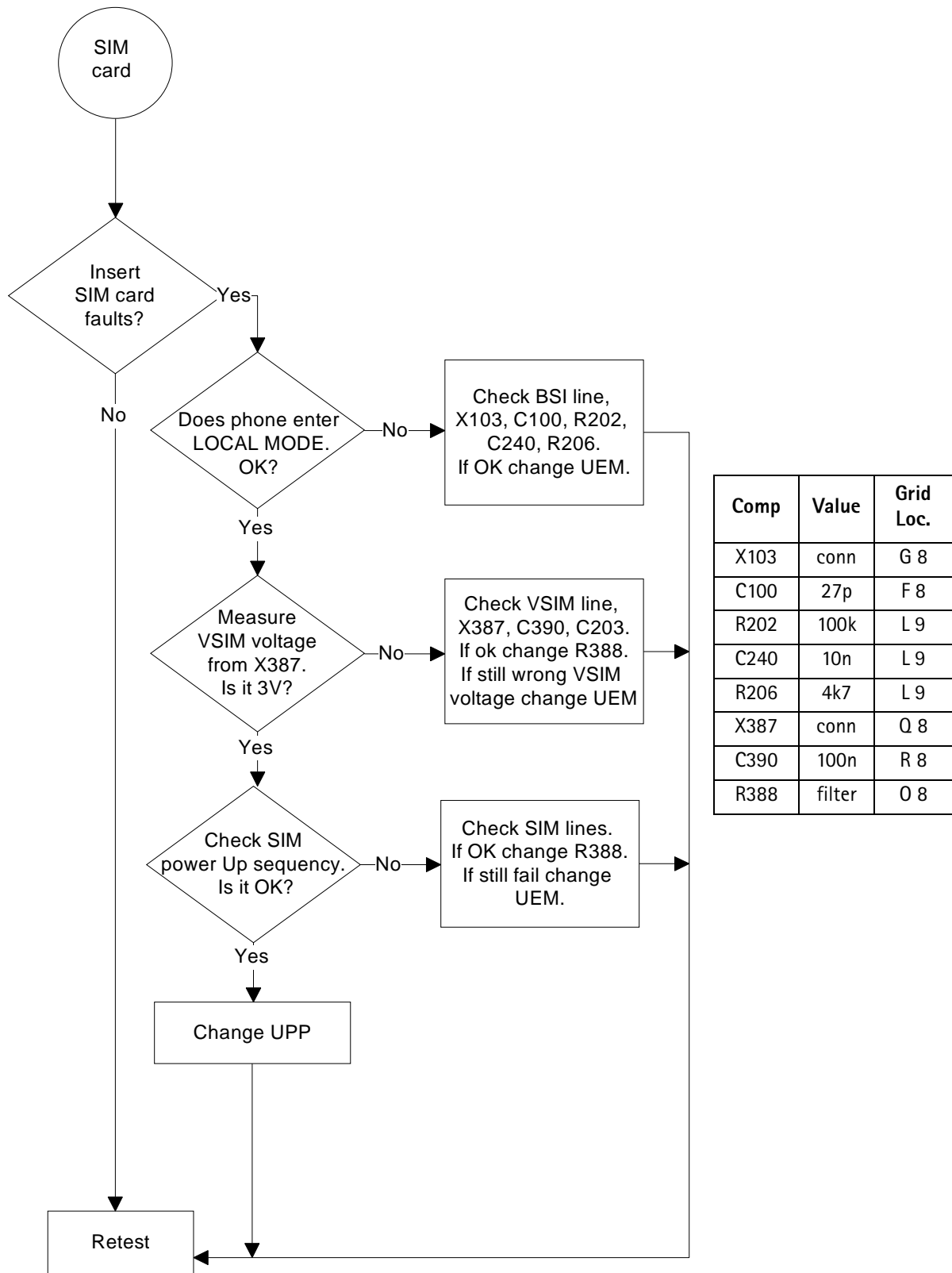

Audio Faults

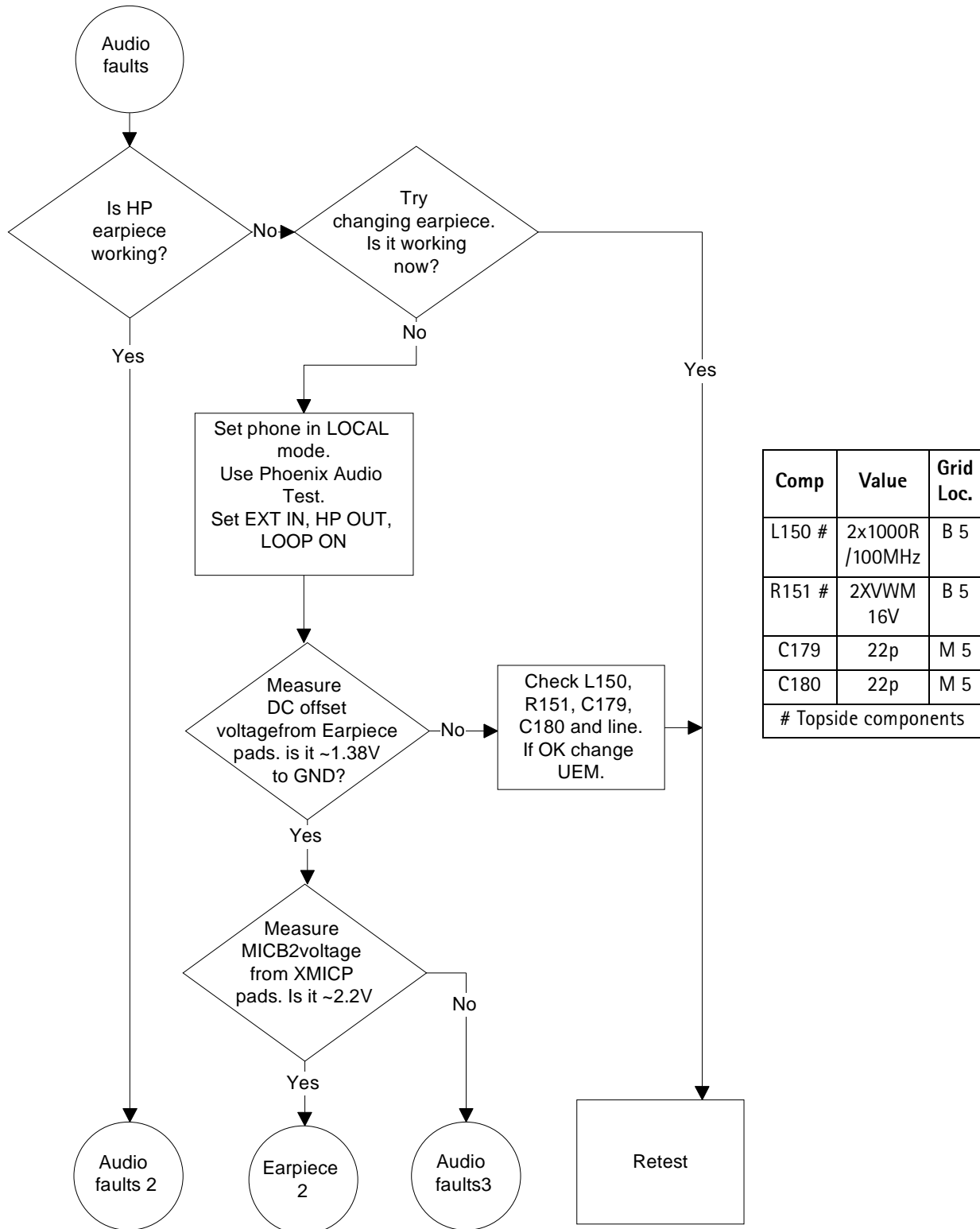

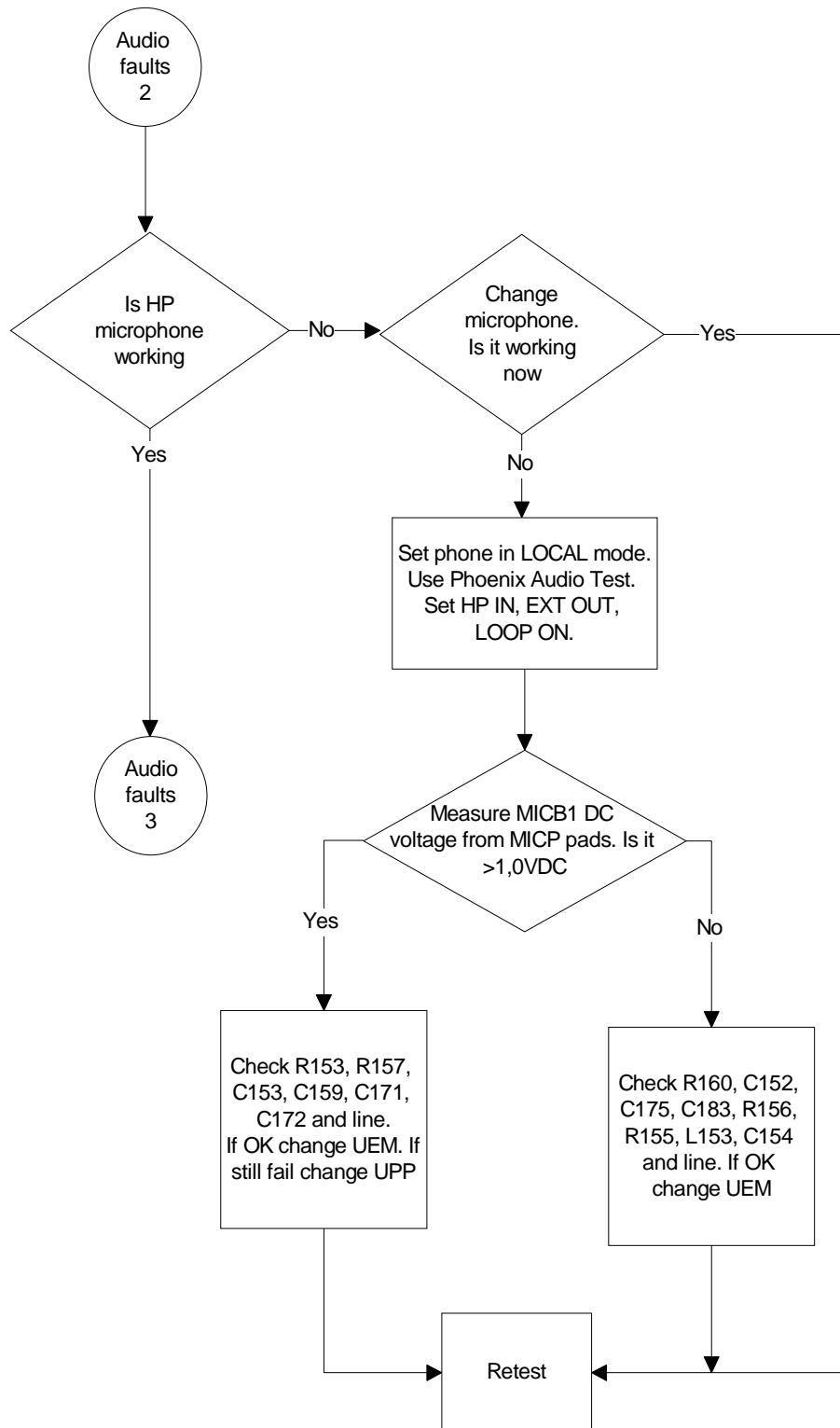

Comp	Value	Grid Loc.
R153	2x2k2	N 7
C153	55n	N 7
C159	33n	N 7
C171	1n0	N 7
C172	1n0	N 7
R160	220R	O 7
C175	2u2	O 7
C183	2u2	O 7
R156	2k2	O 7
R155	2XVWM16V	S 4
L153	600R/100MHz	S 4
C154	22p	S 4

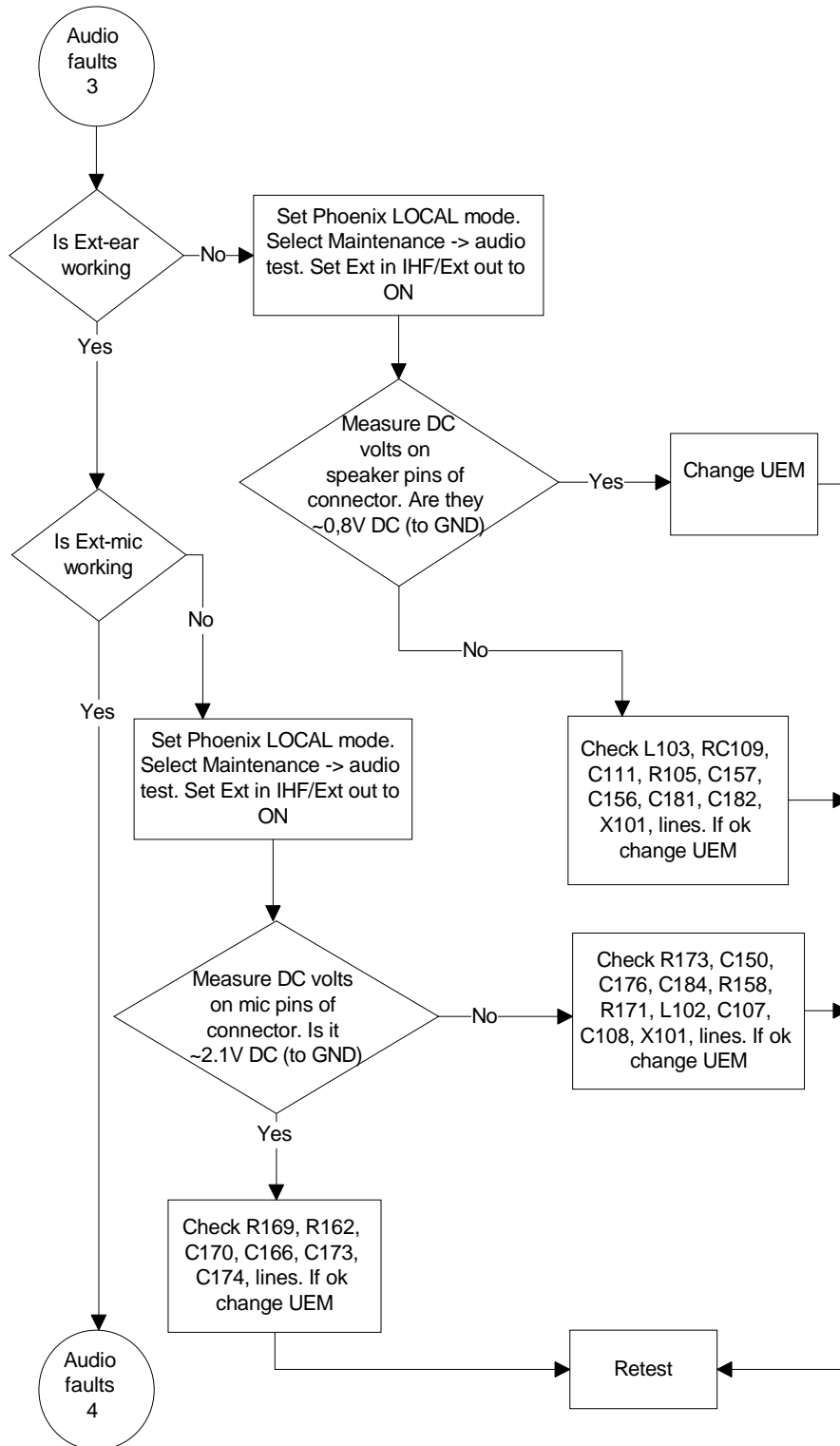

Comp	Value	Grid Loc.
L103 #	2x1000R /100MHz	T 7
C111 #	10n	S 7
C156 #	22p	T 7
C181	22p	O 7
C182	22p	O 7
R173	220R	N 7
C150	4u7	O 7
C176	2u2	O 8
C184	2u2	O 8
R158	820R	O 8
R171	1k0	O 8
L102 #	2x1000R/100MHz	T 7
C107 #	10n	S 7
C108 #	10n	S 7
R162	2x2k2	N 7
C170	33n	N 7
C166	33n	O 7
C173	1n0	N 7
C174	1n0	O 7
R105 #	2XVWM 16V	T 8
C157 #	22p	T 8
C109 #	10n	S7
# Topside components		

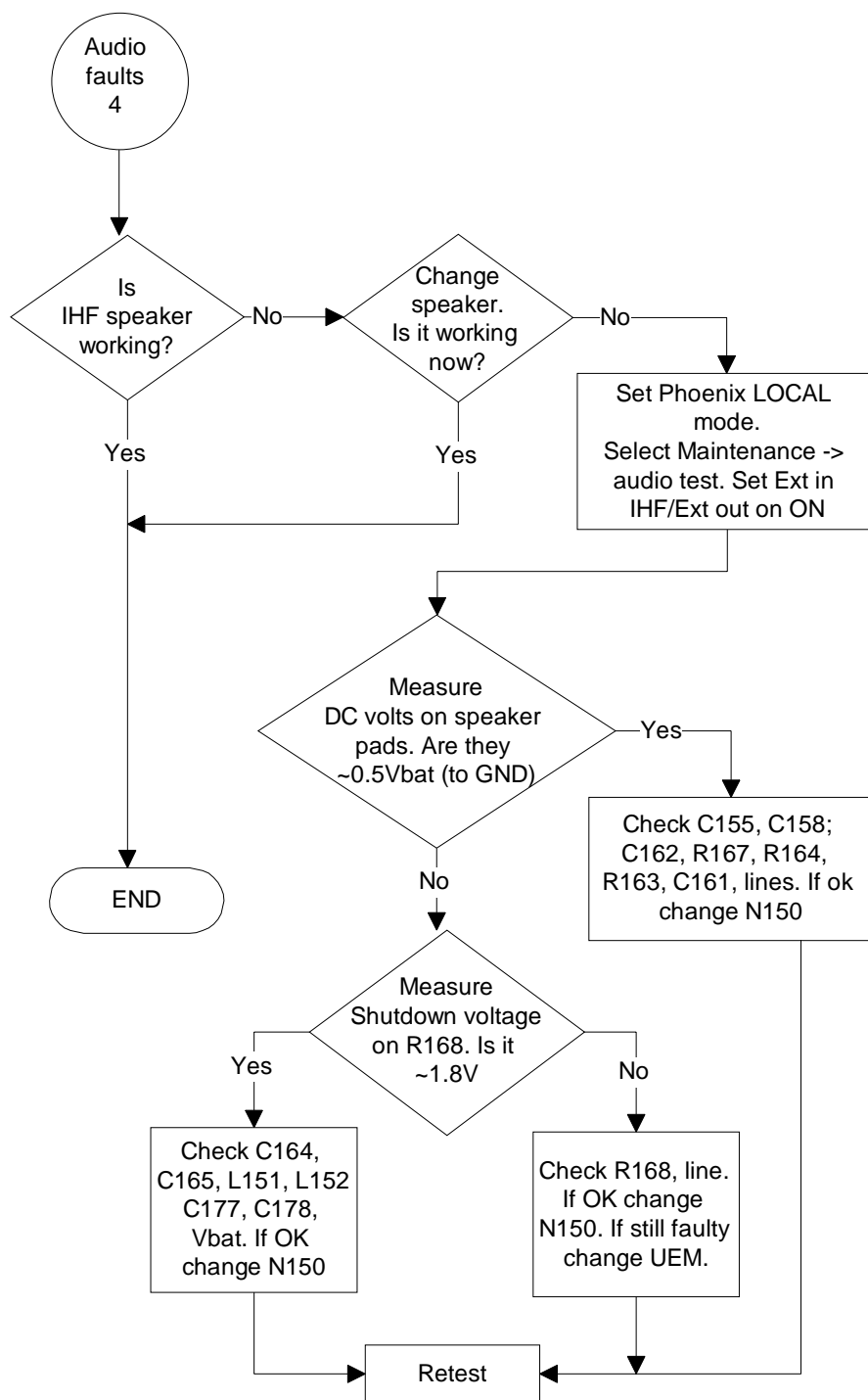

Comp	Value	Grid Loc.
C155	33n	N 6
C158	100n	N 6
C162	100n	N 6
R167	10k	N 6
R164	2x2k2	N 6
R163	18k	N 6
C161	1n0	N 6
N150	-	O 6
C164	22p	N 6
C165	22p	N 6
L151	240R/ 100MHz	E 3
L152	240R/ 100MHz	E 3
C177	47p	E 3
C178	47p	E 3
R168	100k	O 5

Earpiece Fault

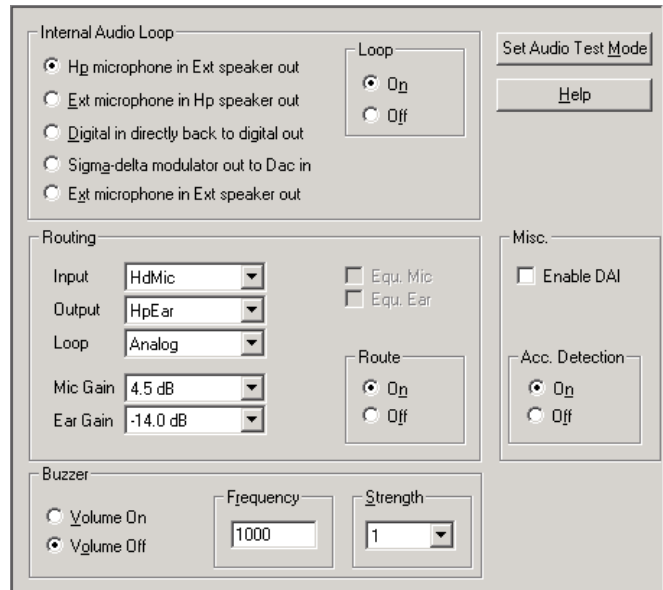
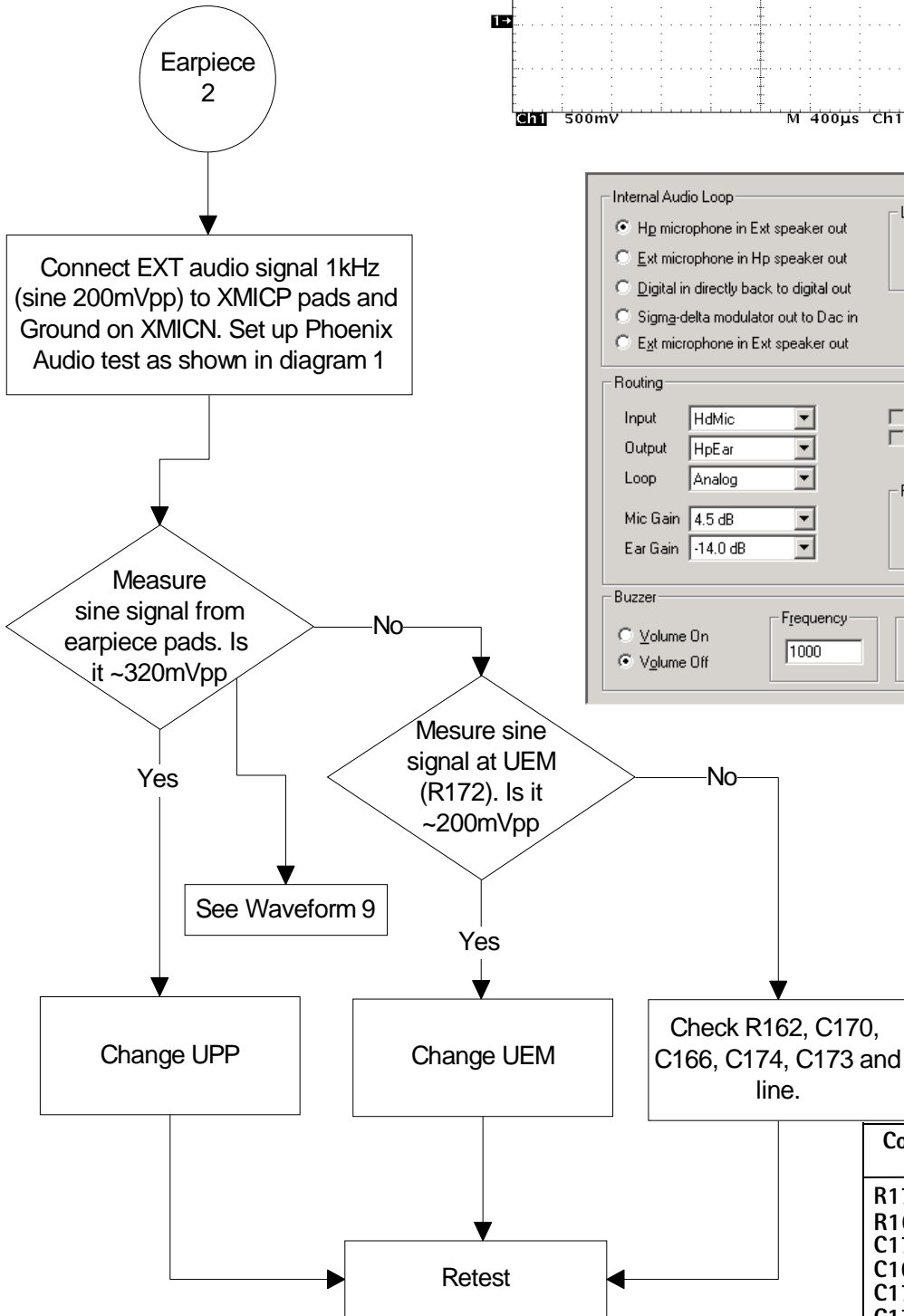
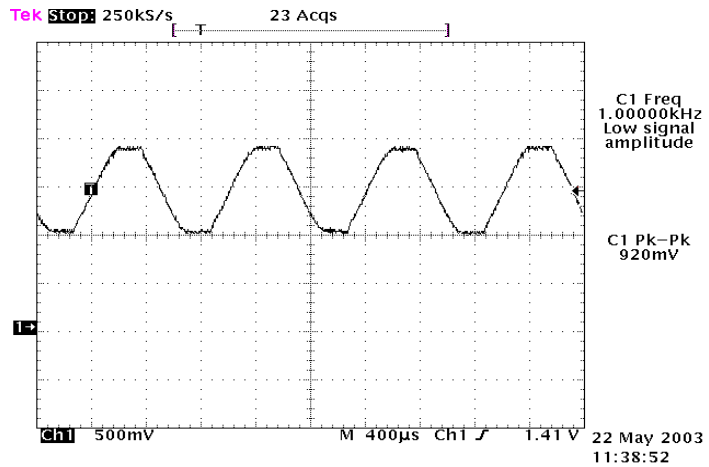

Comp	Value	Grid Loc.
R172	27k	N 7
R162	2x2k2	N 7
C170	33n	N 7
C166	33n	O 7
C174	1n0	O 7
C173	1n0	N 7

Display Fault

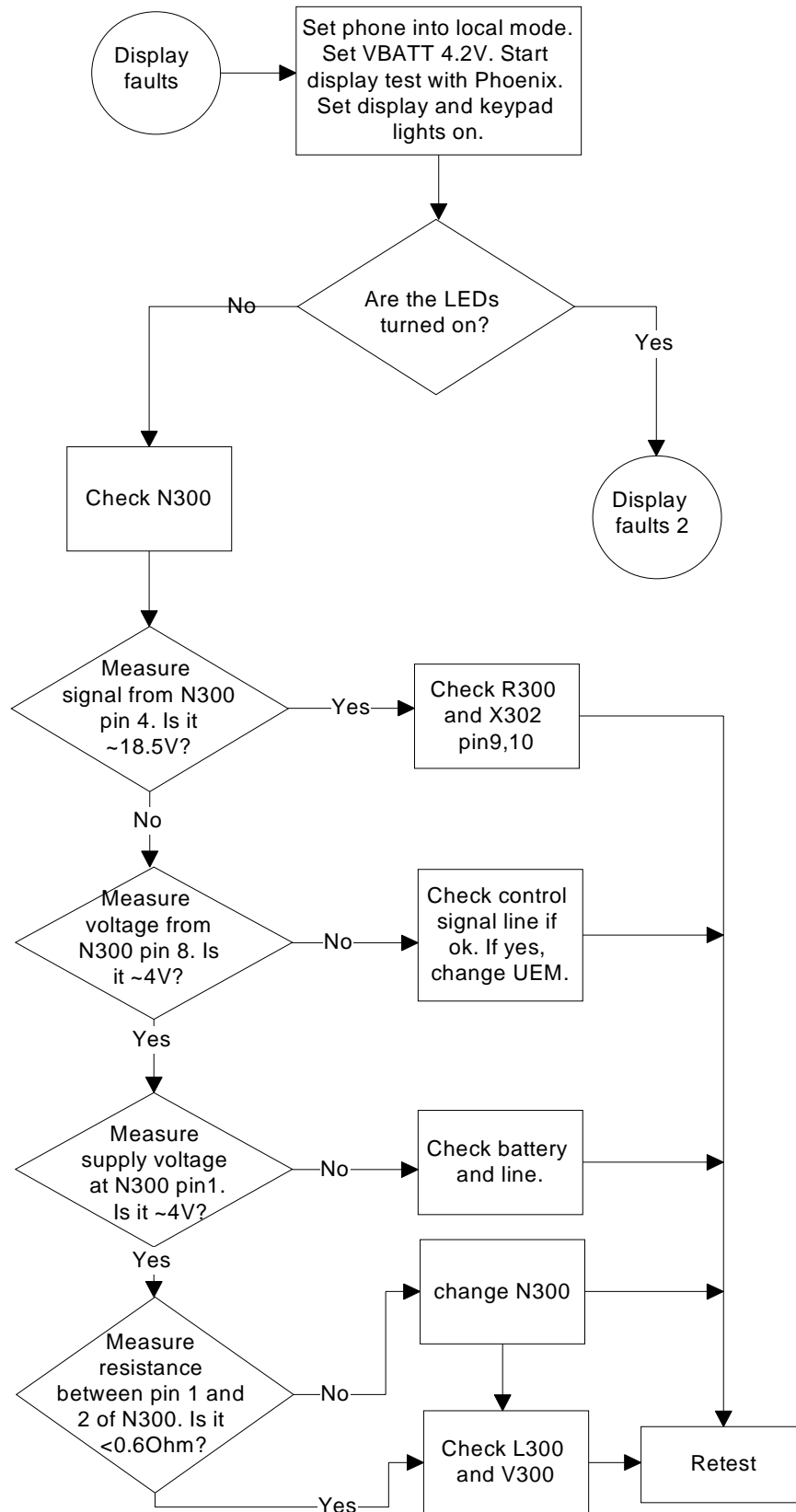

Comp	Value	Grid Loc.
N300	-	N 9
R300	27R	N 9
L300	22uH	N 8
V300	-	N 8
X302	conn	B 7

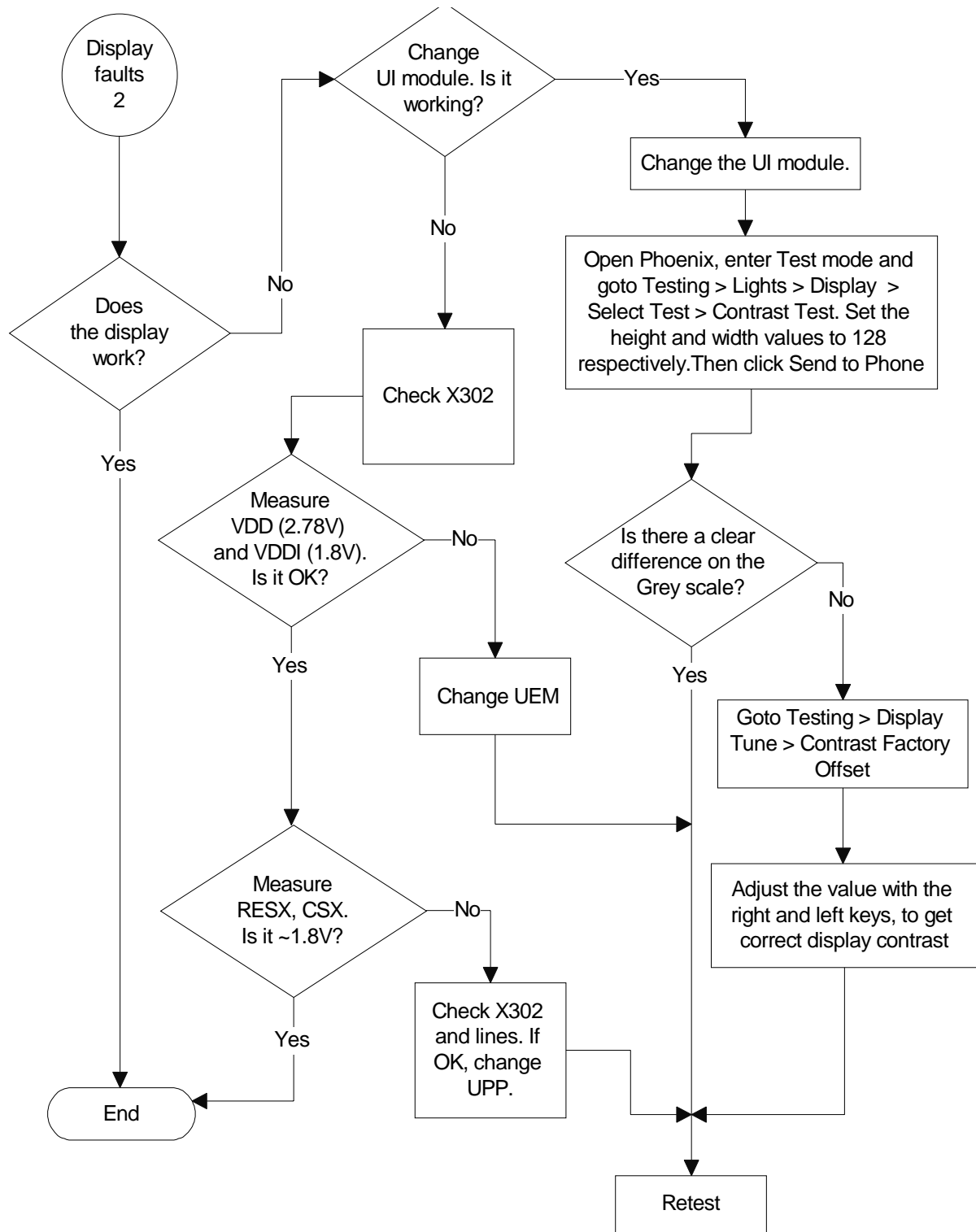

Comp	Value	Grid Loc.
X302	conn	B 7

Keypad Fault

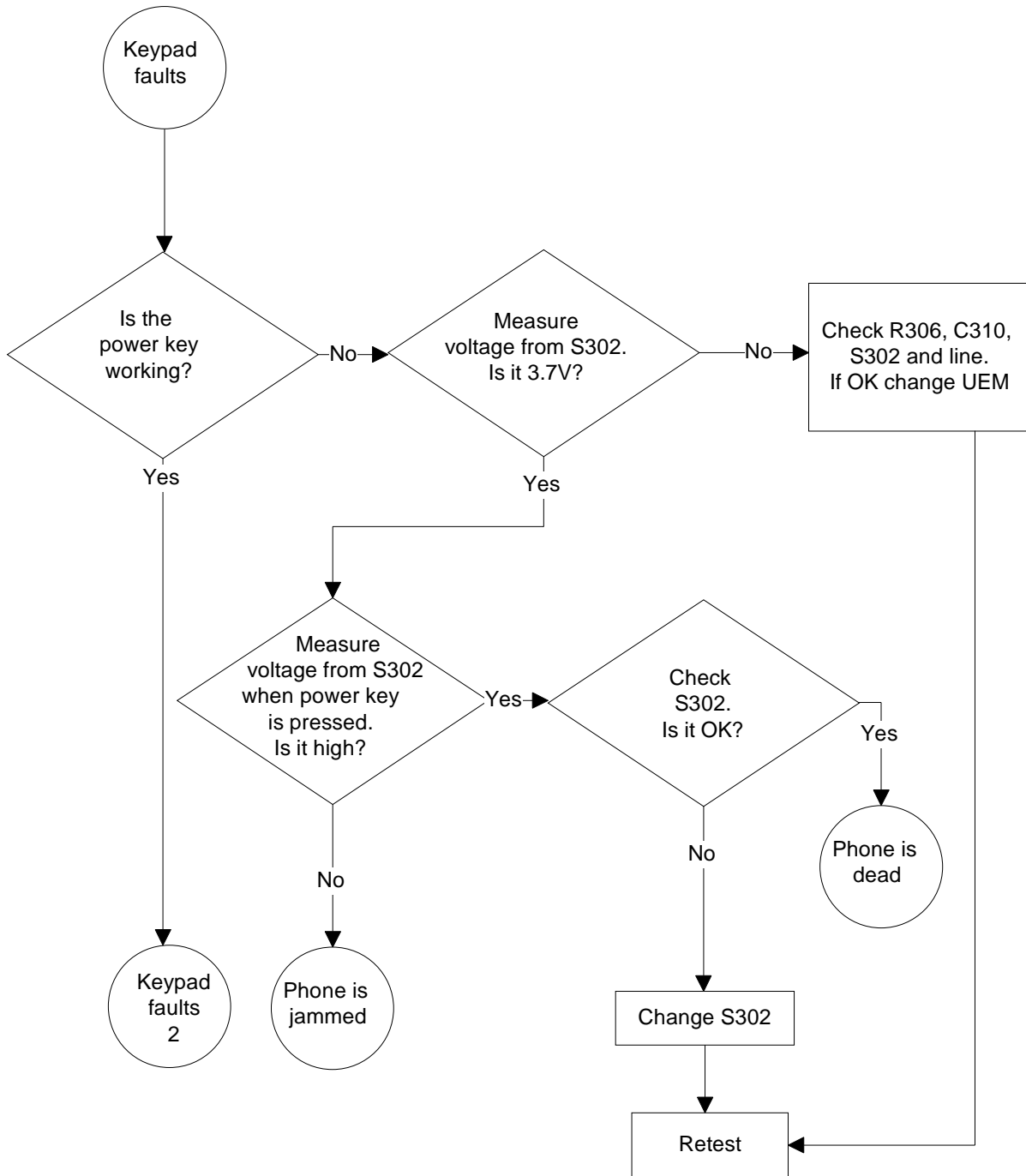

Comp	Value	Grid Loc.
S302	switch	B 6
R306	27k	B 5
C310	22p	B 5

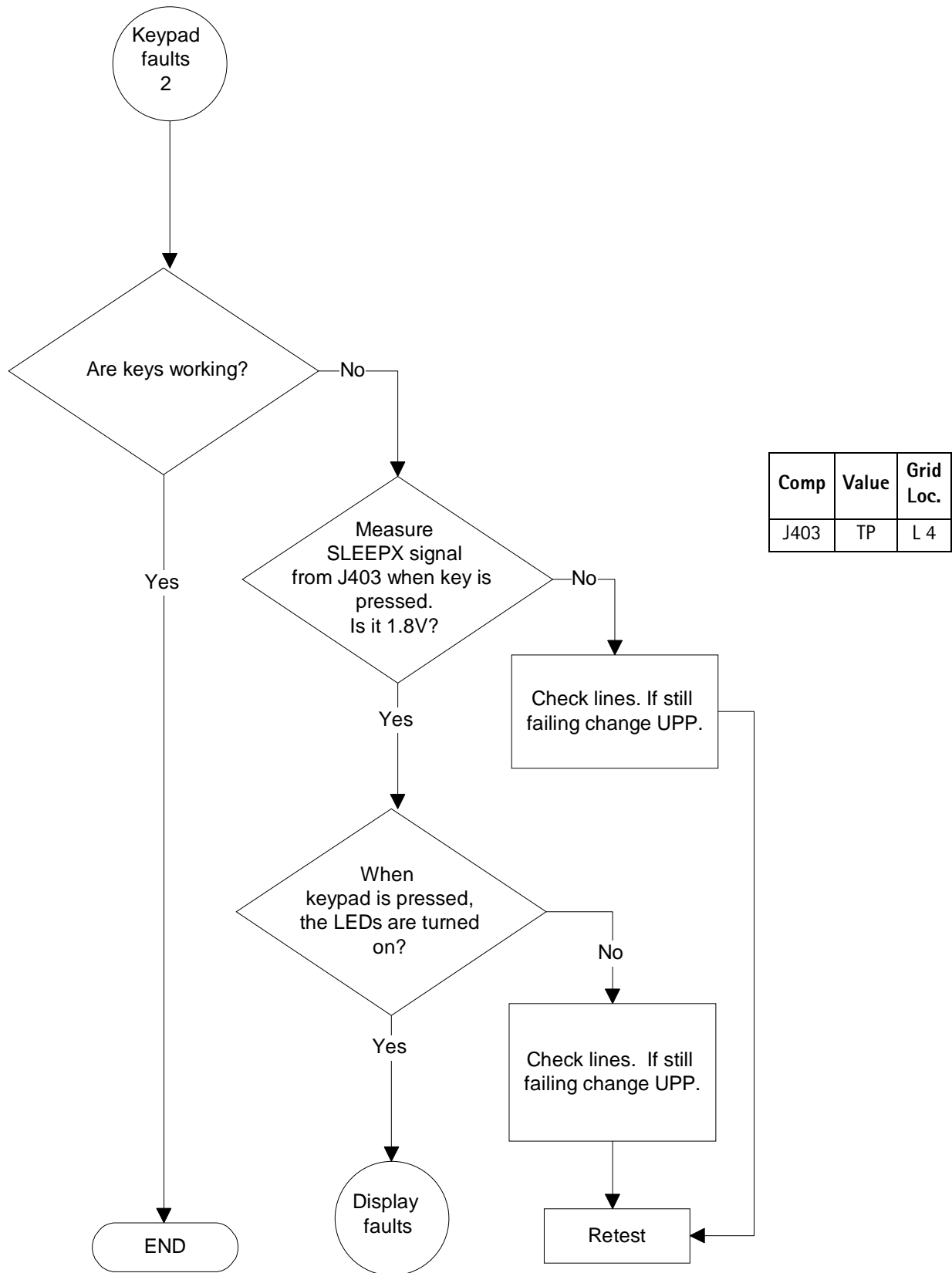

Comp	Value	Grid Loc.
J403	TP	L 4

Selftest Failure

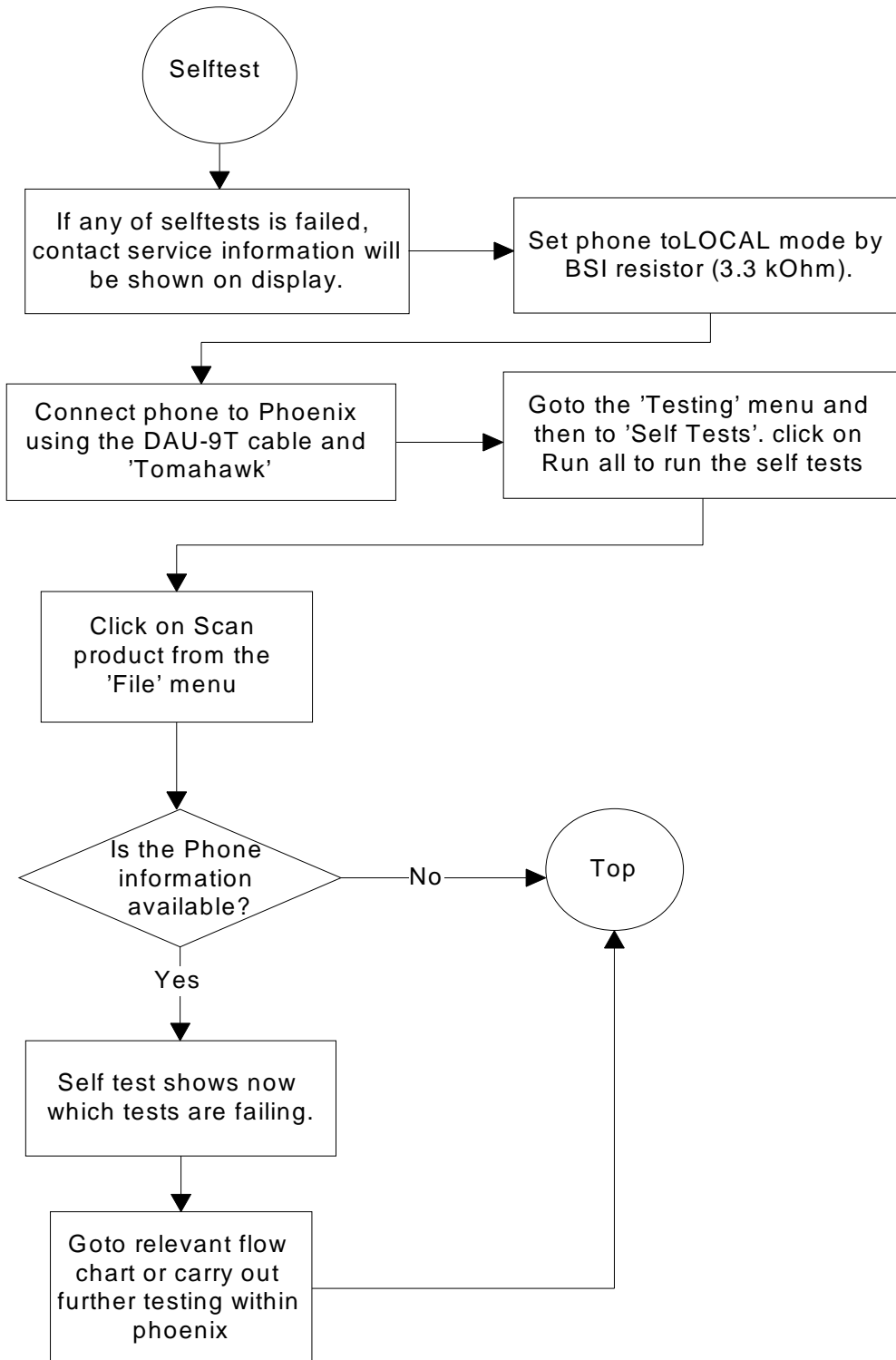

Active Cover Interface

